

# LIFTING MAGNET TML 1000

Oficiální prodejce:

**PAVLÍNEK**  
VÁZACÍ PROSTŘEDKY

Šalounova 746/31  
703 00 Ostrava - Vítkovice  
www.pavlinek.cz

Tel.: +420 595 693 911  
Fax: +420 595 693 958  
E-mail: obchod@pavlinek.cz

- 1 Only 18.0 kg (40 lbs) dead weight
- 2 Max. load-bearing capacity: 1.000 kg (2,200 lbs) (with 3:1 safety factor)
- 3 360° rotatable and 180° pivotable load swivel
- 4 One-handed operation ('inside' steel beam possible)



- Up to 1,000 kg (2,200 lbs) load-bearing capacity from a material thickness of 10 mm (3/8") on steel S235 plus 3:1 safety factor (i.e. the force which leads to the breakaway of the metal sheet must represent triple the maximum holding force)
- Outstanding performance on thin-walled materials (useable from as low as 2 mm; 1/16")
- Up to 70 % less dead weight with at least the same performance in contrast to conventional magnets
- Easy activation with minimal effort due to the ergonomic activation lever
- Innovative operational concept allowing for an enlarged operating range
- 360° rotatable and 180° pivotable load swivel
- Wear-resistant magnetic contact area made of hardened steel with TiN-coating preventing damages and guaranteeing a long lifetime

#### Technical data TML 1000:

- Dead weight: 18.0 kg (40 lbs)
- Breakaway force: > 3,400 kg (7,500 lbs) on 12 mm (1/2") steel S235
- Max. load-bearing capacity: 1,000 kg (2,200 lbs) (with 3:1 safety factor)
- Max. load-bearing capacity during vertical lifts (90° inclination of the load): 300 kg (660 lbs) (from 12 mm; 15/32" on steel S235 with 3:1 safety factor)
- Length: 470 mm (18-1/2") (closed lever), width: 154 mm (6-1/16"), height: 335 mm (13-3/16") (opened lever)
- Magnetic contact area: Length: 387 mm (15-1/4"), width: 92 mm (3-5/8")

Oficiální prodejce:

**PAVLÍNEK**  
VÁZACÍ PROSTŘEDKY

Šalounova 746/31  
703 00 Ostrava - Vítkovice  
www.pavlinek.cz

Tel.: +420 595 693 911  
Fax: +420 595 693 958  
E-mail: obchod@pavlinek.cz

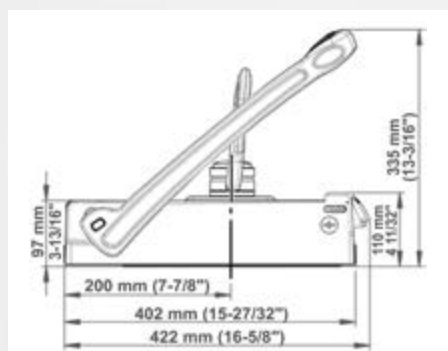

Prod.-No.

ALFRA TML 1000

41700