

KITO



PAVLÍNEK[®]
VÁZACÍ PROSTŘEDKY

BULLETIN NO. ER2GE1809-01
EMAIL: OBCHOD@PAVLINEK.CZ
TEL: +420 595 693 911
ŠALOUNOVA 746/31, OSTRAVA VÍTKOVICE
IČ: 25358511 DIČ: CZ25358511



Smooth & Ergonomic Operation, Reliable Safety, Enhanced Durability

KITO ELECTRIC CHAIN HOIST ER2



Smooth & Ergonomic Operation
Reliable Safety
Enhanced Durability
Easier Maintenance
Environmentally Friendly



Dual speed inverter hoist provided as standard*



Contents

4	ER2 OUTLINE
4	SMOOTH & ERGONOMIC OPERATION
5	RELIABLE SAFETY
6	ENHANCED DURABILITY
6	EASIER MAINTENANCE
7	ENVIRONMENTALLY FRIENDLY
8	ER2 ELECTRIC CHAIN HOIST
9	ER2 ELECTRIC CHAIN HOIST LINEUP
9	TROLLEYS
10	LIFTING & TRAVERSING SPEED
10	PRODUCT CODE
11	CHAIN CONTAINERS
11	PRODUCT CONFIGURATIONS
12	LIFTING MOTOR RATINGS
13	HOIST CLASSIFICATIONS
14	ER2 Single Speed With Hook Suspension
15	ER2 Dual Speed <small>inverter</small> With Hook Suspension
16	ER2M Single Lifting - Single Traversing Speed With Motorized Trolley
17	ER2M Dual Lifting <small>inverter</small> - Dual Traversing Speed <small>inverter</small> With Motorized Trolley
18	ER2SG Single Speed With Geared Trolley
19	ER2SG Dual Speed <small>inverter</small> With Geared Trolley
20	ER2SP Single Speed With Plain Trolley
21	ER2SP Dual Speed <small>inverter</small> With Plain Trolley
22	ER2 Dual Speed 500V <small>pole change</small> With Hook Suspension
23	ER2M Dual Lifting <small>pole change</small> - Dual Traversing Speed 500V <small>pole change</small> With Motorized Trolley
24	ER2SG Dual Speed 500V <small>pole change</small> With Geared Trolley
25	ER2SP Dual Speed 500V <small>pole change</small> With Plain Trolley
26	CDER2 Cylindrical Control Dual/Single Speed with Hook Suspension
27	ER2 Large Capacity With Hook Suspension
28	ER2M Large Capacity With Motorized Trolley
29	ER2SG Large Capacity With Geared Trolley
30	TWER2M Twin Hook
31	SHER2M Ultra Low Headroom
32	Options / Hook Dimensions
33	Net Weight List (With Mechanical Brake with Friction Clutch) Standard 3m Lift
33-35	Applications

*Except for specific voltage



KITO ELECTRIC CHAIN HOIST **ER2**

The new KITO electric chain hoist ER2 has been released as a product that further builds upon KITO's previous ER series. Seeking improved ease of use and work efficiency, an inverter has been provided as standard in a dual speed hoist and trolley. The dual speed inverter delivers smoother movement than ever, reducing load swing.

To ensure safety, KITO utilizes a double safety mechanism consisting of an originally developed friction clutch and upper-lower limit switch. Uniquely-designed push button control on the basis of ergonomics, enhanced durability of load chain, improved ease of maintenance as well as support for the environment achieve higher safety and working efficiency. These products, therefore, provide long-period stable operation, which is essential for improving production efficiency. Due to further improved durability, the increased product service life and reduced running costs have resulted in minimizing the lifetime cost.

KITO electric chain hoists have sought the industry's top level of safety, durability and ease of maintenance, and to continue as highly trusted products selected around the world, the evolution of KITO electric chain hoists continues.

Dual Speed Inverter Hoists with capacities up to 500kg

Hoist Classification **M6 (ISO)**
3m (FEM)

The durability of mechanical components such as gears and bearings is twice higher than M5 (ISO) 2m (FEM)!

ER2 with hoist inverter enables smoother starting and stopping.
The total duration of use is 3200 hours (Subjected regularly to the maximum load).
The increased duration provides better value and performance.



Compact Body

Light weight

The compact aluminum die-cast body has exceptional rigidity as well as, high dust-protection and water-protection. It has a simple structure with a small number of parts. Fine-tuned profile of the load chain link benefits loss of the hoist body weight compared to the previous ER.



ER2 Outline

Rated capacity:	Single speed – 125 kg to 20 t
	Dual speed – 125 kg to 5 t
Voltage:	220-230 V 50/60Hz
	380-415 V 50 Hz 380-440 V 60 Hz
	500 V 50 Hz (pole change for dual speed) 460 V 60 Hz (for specific regions)
Control voltage:	24 V (110 V for specific regions)
Duty rating:	Single speed – 60% ED (60 min.)
	Dual speed – 40/20% ED (30/10 min.)
Classification:	M4, M5, M6 (ISO); 1 Am, 2m, 3m (FEM); H4 (ASME)
Motor insulation:	Class B for 220-230-50/60 and 500-50 (460-60)
	Class F for 380-415-50 and 380-440-60
Enclosure:	Hoist body – IP55, Push button control - IP 65
Suspension varieties:	Hook, manual trolley, motorized trolley
Operating temperature:	-20 to 40 °C (-4 to 104 °F)
Operating humidity:	85%RH or less

Smooth & Ergonomic Operation

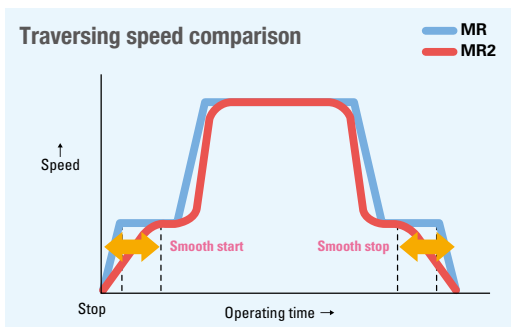
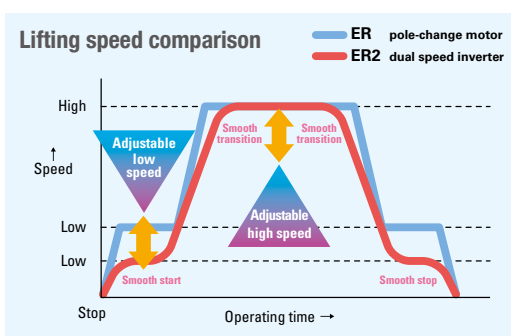

Inverter

smooth transitional speed

The dual speed inverter delivers smoother movement than the pole change motor, reducing load swing. The high to low speed ratio can be set to a large value. This results in smooth starts, improved low speed stops, and improved positioning accuracy. The standard speed ratio is 6:1 adjustable up to 12:1* for lifting and 10:1* for traversing.

ER2/MR2 inverter unit is well-customized for lifting/traversing applications including exclusive software with optimum control and is also provided with measures against impact and heat which were verified through long run tests.

*For a speed ratio other than the standard, please make a request at the time of placing an order.



PAVLÍNEK[®]
VÁZACÍ PROSTŘEDKY

EMAIL: OBCHOD@PAVLINEK.CZ
TEL: +420 595 693 911
ŠALOUNOVA 746/31, OSTRAVA VÍTKOVICE
IČ: 25358511 DIČ: CZ25358511



Accelerating and decelerating time in addition to speed are adjustable for dual speed inverter trolley.



Push button control **original design**

The push button control is designed in an ergonomic shape that is operator friendly. Seeking ease of operation and universal design, KITO's original push button control was designed and manufactured based on trial and error repeated many times, in particular, upgrading prototypes and evaluation from an enduser point of view especially with respect to unit strength.

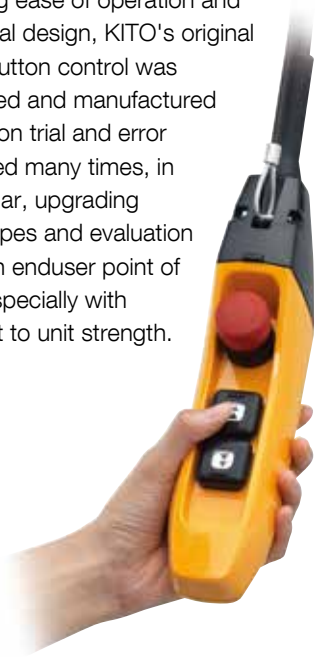

Contoured to comfortably fit into your hand. The button has a light operating sensation which responds to fine adjustments in pressure. The pressing stroke is short. The operator, therefore, will not become fatigued after long-periods of operation.



Back lug for firm grip



As for a crane fabrication with a motorized end truck, a control box is available if necessary.

Resistant to the collisions and shocks that may occur during work, KITO's original push button control can be used in various environments, thus supporting efficient work.



Load sheave **reduced vibration**

Increasing the number of load sheave pockets helps relieve vibrations produced by the revolving polygonal sheave on the hoist's body and load chain.



Reliable Safety

Friction clutch & upper-lower limit switch **double safety**

Maintaining safety is the most important task for lifting equipment, and is essential for stable operation. To ensure safety, KITO utilizes a double safety mechanism consisting of an originally developed friction clutch and upper-lower limit switch.

The friction clutch is an emergency overload protection device that idles the motor when subjected to an excessive load over the rated capacity. Friction clutch performance is not easily compromised with changes in the surrounding temperature. In the case of irregular loading, this operates in advance to prevent the hoist body or load chain from being damaged.



In the event that a load is lifted or lowered excessively, the limit switch stops the motor, preventing hoist or load chain damage. (Not regular use)



Thermal protector

To prevent the motor from burning out due to excessive usage, a standard thermal protector is installed in the motor.

Electromagnetic brake **fail-safe connection**

Connected in series to a motor circuit, a current-driven electromagnetic brake does not release unless the motor is energized. This concurrent drive increases safety of the circuit compared to separate circuits for the motor and the brake.

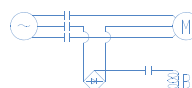

Emergency stop

The emergency stop, provided as standard, allows the motor power to be disconnected in an emergency without cutting off the main power supply.



Enhanced Durability

High end duty rating

The ER2 achieves M6(ISO)/3m(FEM) class (refer to section of "Hoist Classifications"), with a duty cycle of 60% ED. Supporting use in the most demanding environments and conditions, this long service life hoist is a heavy-duty product which is also applicable to high frequency or long lift operations.

The gearbox is lubricated in an oil bath. As a result of this, wear and tear has been improved and cooling has also been enhanced at the same time.

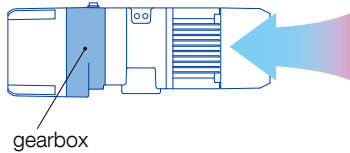

Unique motor frame fins & fan cover

A unique fan-cooled motor with motor frame fins and a fan cover have been configured into a purpose built design. This design produces a much quieter motor unit as well as enhanced fan cooling capabilities.



Load chain **super strength**

KITO's world class original super-strength nickel-plated load chain certified by German Institute, uses unique technology to greatly increase resistance to fatigue and wear.



Load chain wear comparison

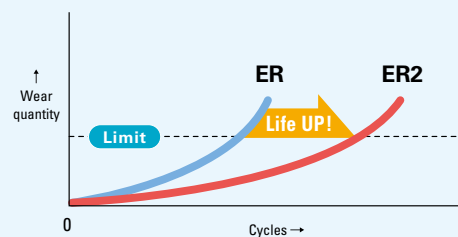

At KITO, testing is continuously being carried out regarding the load chain fatigue, wear, tensile strength, and environment. KITO takes pride in manufacturing load chains that have strength, durability and accuracy for utilization in the product. **ER2 chains are not compatible with that of the previous ER hoist series due to a difference of their chain profile.**

PAVLÍNEK[®]
VÁZACÍ PROSTŘEDKY

EMAIL: OBCHOD@PAVLINEK.CZ
TEL: +420 595 693 911
ŠALOUNOVA 746/31, OSTRAVA VÍTKOVICE
IČ: 25358511 DIČ: CZ25358511



Easier Maintenance

Connecting shaft & cover belt

The connecting shaft that was previously attached inside the body is now mounted on the outside of the ER2. This allows a top hook or suspender to be attached or removed with ease.

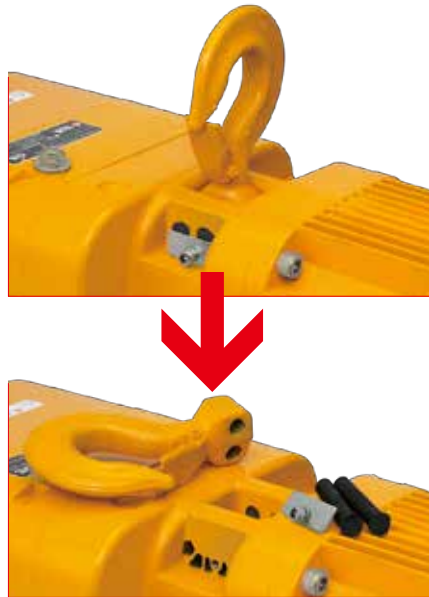

The electric parts and equipment are contained inside the controller cover. Therefore, inspection and parts replacement can be accomplished easily. The controller cover is connected to the hoist body using a cover belt so that maintenance can be carried out more easily.



CH (counter hour) meter

As a standard feature, the hoist's total on-time and the number of lowering starts are shown on the LCD of the CH meter. This enables the user to carry out maintenance based upon the frequency of use. By maintaining a history of the CH meter data, the inspection periods and replacement periods for gear oil, contactors, brakes and load chains can be efficiently controlled, allowing the equipment to be used with confidence.



Dual speed



Single speed

Environmentally Friendly

No hazardous substances

As an environmental measure, several environmentally hazardous substances specified by KITO, including 6 European RoHS directive substances, are not used.

Energy saving

Further, an energy-savings can be made due to reduction in rated current draw compared to the previous ER.

Lower noise

The utilization of the inverter, 4-pole motor as well as the electromagnetic brake, reduces the noise during operation and braking.



PAVLÍNEK[®]
VÁZACÍ PROSTŘEDKY

EMAIL: OBCHOD@PAVLINEK.CZ
TEL: +420 595 693 911
ŠALOUNOVA 746/31, OSTRAVA VÍTKOVICE
IČ: 25358511 DIČ: CZ25358511



ER2 Electric Chain Hoist

Electromagnetic brake

Current-driven electromagnetic brake produces strong braking power, securely holding a load.

External motor fan

Aluminum die-cast motor frame with external motor fan reduces rise in heating during frequent operation.

Chain guide

KITO's uniquely-structured for smooth chain-feeding.

Gears

Helical gears reduces operating noise.

Chain container

Durable plastic or canvas containers as standard.



Direct wiring available

Plug connection

Easily attached and removed

Load chain

Nickel-plated load chain standard, manufactured through KITO's own technology to provide a higher resistance against fatigue, wear and rust. The load chain is made from a unique alloy-steel designed of KITO's study and experience, which is produced under high quality control through automated facilities from material incoming to chain completion. The load chain is manufactured with hard surface to increase wear resistance and is well-balanced between its strength and toughness in the core section.

Hook

Equipped with a bearing and characterized by gradual elongation, not sudden breakage under overload conditions. The notched latch for firm contact improves resistance against lateral force.

Push button control

Originally designed with emergency stop provided as standard that is both operator friendly and has greater durability.

Thermal protector

Sensor overheating to shut off the current.

Connecting shaft

The connecting shaft is mounted on the outside of the body. This allows the top hook or suspender to be attached or removed with ease (except for Body F).

Aluminum die-cast body

Tough body

Enclosure

Dust-protected and jet-protected (IP55)

Electromagnetic contactor

Mechanically interlocked to prevent multi-switching at the same time

CH meter built-in inverter

Recording and displaying no. of lowering starts and the hoist on-time enable right maintenance appropriate for operational frequency.

Friction clutch

Originally developed as an emergency overload protection by KITO to slip the force from the motor in such lifting an anchored object.

Upper-lower limit switch

Simplified structure - stops the hoist at both ends of the hook path as a double safety mechanism with Friction clutch. (Not regular use)

Cover belt

Attached to the controller cover and gear case convenient for maintenance.



PAVLÍNEK[®]
VÁZACÍ PROSTŘEDKY

EMAIL: OBCHOD@PAVLINEK.CZ
TEL: +420 595 693 911
ŠALOUNOVA 746/31, OSTRAVA VÍTKOVICE
IČ: 25358511 DIČ: CZ25358511



ER2 Electric Chain Hoist Lineup

Type	Lifting speed		Capacity (t)														
			125kg	250kg	500kg	1	1.5	2	2.5	3	5	Large capacity					
													7.5	10	15	20	
Hook suspension ER2	Single	Low			•	•		•									
		Standard		•	•	•	•	•	•	•	•			•	•	•	
		High	•	•													
	Dual inverter	Low			•	•		•									
		Standard		•	•	•	•	•	•	•	•						
		High	•	•													
Trolley suspension Motorized trolley ER2M Plain Trolley ER2SP (up to 5t) Geared Trolley ER2SG	Single	Low			•	•		•						•			
		Standard		•	•	•	•	•	•	•	•			•	•	•	•
		High	•	•													
	Dual inverter	Low			•	•		•									
		Standard		•	•	•	•	•	•	•	•						
		High	•	•													

KITO will not be held liable for any malfunction, lack of performance or accident if the product is being used in conjunction with any other equipment. If the product is to be used for unintended purposes, please confirm with your dealer in advance.

Trolleys

Motorized Trolley MR2

Bearing built-in side rollers provide smooth running through the minimum radius curve and excellent traversing performance with preventive derailment.

Features

- Simple gear box construction
- Improved balance due to a lighter weight geared motor
- Speed variations
 - Single Low Speed
 - Single Standard Speed
 - Dual Speed

Plain & Geared Trolley

- Designed to provide smooth and easy traversing.
- Lugs provide protection from striking damage against rail stoppers, and from falling off the rail.
- Wheel flanges also prevent derailment.

Plain Trolley TSP

Designed for light load manual applications (125kg to 5t)

Geared Trolley TSG

Designed for precise positioning and traversing by using hand chain (125kg to 20t)

Motorized Trolley MR2



125kg to 20t

Plain Trolley TSP



125kg to 3t



5t

Geared Trolley TSG



125kg to 3t



5t to 20t



PAVLÍNEK[®]
VÁZACÍ PROSTŘEDKY

EMAIL: OBCHOD@PAVLINEK.CZ
TEL: +420 595 693 911
ŠALOUNOVA 746/31, OSTRAVA VÍTKOVICE
IČ: 25358511 DIČ: CZ25358511





Lifting & Traversing Speed

Lifting Speed

(m/min)

Capacity (t)	Single Speed						Dual Speed					
	50 Hz			60 Hz			50/60 Hz*			500 V		
	Low	Standard	High	Low	Standard	High	Low	Standard	High	Low	Standard	High
125kg			14.1			16.9			1.4 to 16.6			14.2/3.5
250kg		9.1	13.4		10.9	16.1		0.9 to 10.8	1.3 to 15.7		7.2/1.8	
500kg	3.8	7.3		4.6	8.8		0.4 to 4.5	0.7 to 8.5		3.6/0.9	7.1/1.8	
1	3.5	7.1		4.2	8.5		0.3 to 4.2	0.7 to 8.2		3.5/0.9	7.2/7.1	
1.5		4.5			5.4			0.4 to 5.3			4.8/1.2	
2	3.7	7.0		4.4	8.4		0.4 to 4.3	0.7 to 8.2		3.7/0.9	6.9/1.6	
2.5		5.7			6.8			0.6 to 6.6			5.5/1.3	
3		4.4			5.3			0.4 to 5.2			4.4/1.0	
5		2.9			3.5			0.3 to 3.3			2.8/0.6	
7.5		1.9			2.3							
10	1.4	2.9		1.7	3.5							
15		1.9			2.3							
20		1.4			1.7							

Note: The speed ratio of inverter hoists is preset to 6:1 in KITO factory.

Traversing Speed

(m/min)

Capacity (t)	Single Speed				Dual Speed	
	50 Hz		60 Hz		50/60 Hz*	500 V
	Low	Standard	Low	Standard	Standard	Standard
125kg to 5	10	20	12	24	2.4 to 24	20/10
7.5 to 20	10		12			

Note: The speed ratio of inverter trolleys is preset to 6:1 in KITO factory.

Product Code

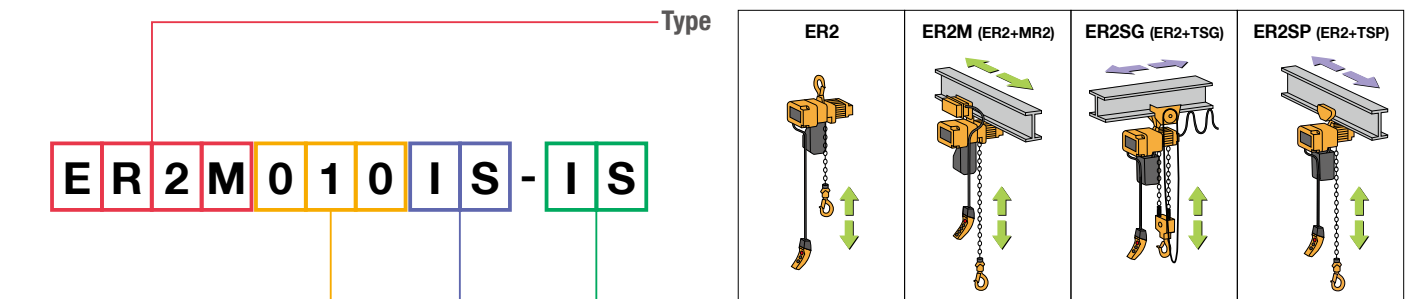

Capacity

Code	Capacity
001	125 kg
003	250 kg
005	500 kg
010	1 t
015	1.5 t
020	2 t
025	2.5 t
030	3 t
050	5 t
075	7.5 t
100	10 t
150	15 t
200	20 t

Lifting speed

Code	Lifting speed
S	single, standard
L	single, low
H	single, high
IS	inverter dual, standard
IL	inverter dual, low
IH	inverter dual, high
SD	dual, standard
LD	dual, low
HD	dual, high

Traversing speed

Code	Traversing speed
S	single, standard
L	single, low
IS	inverter dual, standard
SD	dual, standard

Ex. for ER2M010IS-IS, the electric chain hoist bears "ER2-010IS" as a product code and the motorized trolley "MR2-010IS".

Chain Containers

Type of containers

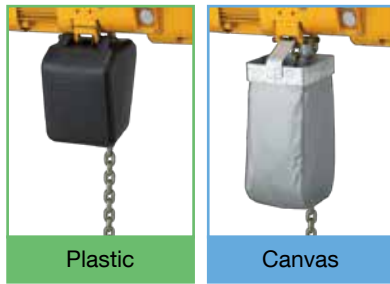

Product code	Body	≤4m	4.1 ≤6m	6.1 ≤8m	8.1 ≤9m	9.1 ≤12m	12.1 ≤15m	15.1 ≤18m	18.1m<
ER2-001H/IH	B								
ER2-003S/IS									
ER2-003H/IH	C								
ER2-005L/IL									
ER2-005S/IS	D								
ER2-010L/IL									
ER2-010S/IS	E								
ER2-015S/IS									
ER2-020L/IL	F								
ER2-020S/IS									
ER2-025S/IS	E								
ER2-030S/IS									
ER2-050S/IS	F								
ER2-075S									
ER2-100L									
ER2-100S									
ER2-150S									
ER2-200S									

Containers are installed differently depending on the types of the products or lift.
The steel containers may not cover the standard curve radii depending on their installation conditions.

Product Configurations

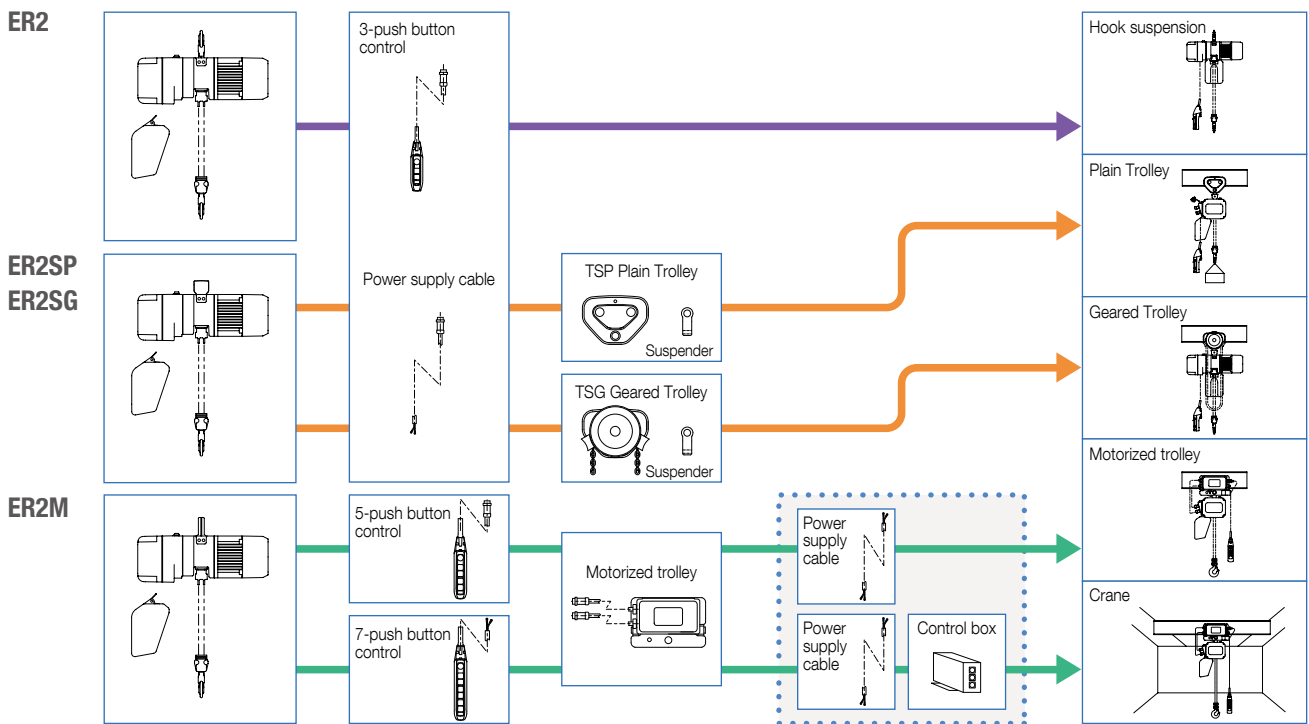

The following types of the hoist are configured differently from the above: Large capacities (7.5t or more), ER2SG/SP for crane, TWER2M and SHER2M



PAVLÍNEK[®]
VÁZACÍ PROSTŘEDKY

EMAIL: OBCHOD@PAVLINEK.CZ
TEL: +420 595 693 911
ŠALOUNOVA 746/31, OSTRAVA VÍTKOVICE
IČ: 25358511 DIČ: CZ25358511



Lifting Motor Ratings

Short Time Rating

This rating indicates how long the hoist can be operated continuously on the below cycle, assuming continued operation for a short time span.

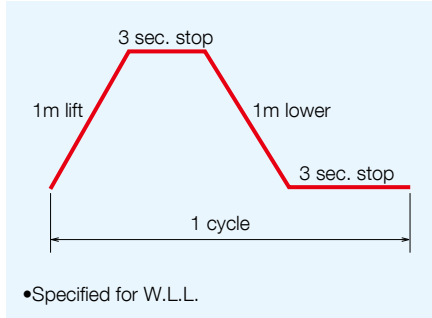

- Single Speed: 60min
- Dual Speed: 30/10min

Intermittent Rating (Percent ED) Max. Number of Starts Per Hour

This rating indicates the ED percent (ratio of motor ON-to-OFF time) and max. number of starts per hour (how many times the motor is started up in one hour)

for a hoist operated continuously on the below cycle, assuming continued operation or repeated starting over a long time span.

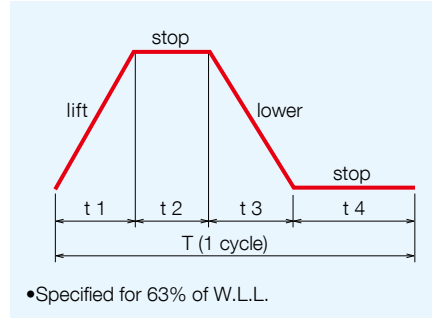

In the case of single speed:

$$\%ED = \frac{\text{Motor ON time (} t_1+t_3 \text{)}}{1 \text{ cycle (} T \text{)}} \times 100$$

$$T = 1 \text{ cycle (} t_1+t_2+t_3+t_4 \text{)}$$

(Within 10 minutes)

%ED and max. number of starts per hour

- Single Speed: 60%ED, 360 starts/hr
- Dual Speed: 40/20 %ED, 240/120 starts/hr



PAVLÍNEK[®]
VÁZACÍ PROSTŘEDKY

EMAIL: OBCHOD@PAVLINEK.CZ
TEL: +420 595 693 911
ŠALOUNOVA 746/31, OSTRAVA VÍTKOVICE
IČ: 25358511 DIČ: CZ25358511





Hoist Classifications

ISO/JIS

State of loading		Total duration of use (h)							
		200	400	800	1600	3200	6300	12500	25000
Light	Mechanisms subjected very rarely to the maximum load and, normally, to light loads	–	–	M1	M2	M3	M4	M5	M6
Moderate	Mechanisms subjected fairly frequently to the maximum load but, normally, to rather moderate loads	–	M1	M2	M3	M4	M5	M6	–
Heavy	Mechanisms subjected frequently to the maximum load and, normally, to loads of heavy magnitude	M1	M2	M3	M4	M5	M6	–	–
Very heavy	Mechanisms subjected regularly to the maximum load	M2	M3	M4	M5	M6	–	–	–

This classification refers to ISO 4301-1 and applies to the mechanical components including gears and bearings except for consumable parts.

ASME HST

Hoist duty class	Typical areas of application	Operation time ratings at $K=0.65$			
		Uniformly distributed work periods		Infrequent work periods	
		Max. on time, min/ hr	Max. No. starts/ hr	Max. on time from cold start, min	Max. No. of starts
H2	Light machine shop fabricating, service, and maintenance; loads and utilization randomly distributed; rated loads infrequently handled	7.6 (12.5%)	75	15	100
H3	General machine shop fabricating, assembly, storage, and warehousing; loads and utilization randomly distributed	15 (25%)	150	30	200
H4	High volume handling in steel warehouses, machine shops, fabricating plants and mills, and foundries; manual or automatic cycling operations in heat treating and plating; loads at or near rated load frequently handled	30 (50%)	300	30	300

The grade symbols are identical to those of ASME HST-1M. (Performance standard for Electric Chain Hoist)

FEM Relation between ISO-and FEM-Denominations

1 D _m	1 C _m	1 B _m	1 A _m	2 m	3 m	4 m	5 m
M 1	M 2	M 3	M 4	M 5	M 6	M 7	M 8

Load spectrum	Cubic mean value	Class of operation time									
		V 0.06	V 0.02	V 0.25	V 0.5	V 1	V 2	V 3	V 4	V 5	
		T 0	T 1	T 2	T 3	T 4	T 5	T 6	T 7	T 8	
		Average operating time per day in hours									
		≤0.12	≤0.25	≤0.5	≤1	≤2	≤4	≤8	≤16	>16	
1 L1	$K \leq 0.50$	–	–	1 D _m	1 C _m	1 B _m	1 A _m	2 m	3 m	4 m	
2 L2	$0.50 < K \leq 0.63$	–	1 D _m	1 C _m	1 B _m	1 A _m	2 m	3 m	4 m	5 m	
3 L3	$0.63 < K \leq 0.80$	1 D _m	1 C _m	1 B _m	1 A _m	2 m	3 m	4 m	5 m	–	
4 L4	$0.80 < K \leq 1.00$	1 C _m	1 B _m	1 A _m	2 m	3 m	4 m	5 m	–	–	

Class of operating time		Average operating time per day (in hours)	Calculated total operating time (in hours)
V0.06	T0	≤0.12	200
V0.12	T1	≤0.25	400
V0.25	T2	≤0.5	800
V0.5	T3	≤1	1,600
V1	T4	≤2	3,200
V2	T5	≤4	6,300
V3	T6	≤8	12,500
V4	T7	≤16	25,000
V5	T8	>16	50,000

The grade symbols are identical to those of FEM 9.511. (Rules for Design of Serial Lifting Equipment: Classification of Mechanisms)



With Hook Suspension

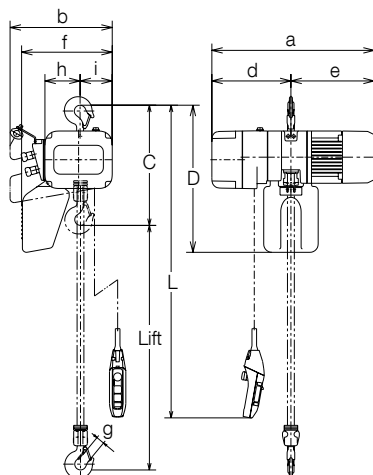

- Standard length of power supply cable is five meters.
- Optional length of lift, push button cord and power supply cable besides standard is available on your request.
- Extending the load chain is prohibited with additional links.
- Steel chain containers are available as option as shown in Section of "Chain Containers" if your lift is more than capacity of the standard container volume.

Specifications

Capacity (t)	Product Code	Hoist Body	Standard Lift (m)	Lifting Motor		Lifting Speed (m/min)		Load Chain		Classification ISO/FEM/ASME	Test Load (t)	Net Weight (kg)	Additional Weight per 1m Lift (kg)
				Output (kW)	Rating (%ED)	50Hz	60Hz	Diameter (mm)	Chain Falls				
125kg	ER2-001H	B		0.56		14.1	16.9	ø4.3	x 1		156kg	27	0.42
250kg	ER2-003S					9.1	10.9				313kg		
		ER2-003H	0.9		13.4	16.1	ø6.0	x 1	M5/2m/H4	625kg		37	
500kg	ER2-005L	C		0.56		3.8				4.6	ø7.7	x 1	
						ER2-005S	0.9		7.3	8.8			
1	ER2-010L	D	3		60	3.5	4.2	ø10.2	x 1		1.88	72	
						ER2-010S	7.1						
1.5	ER2-015S	E		1.8		4.5	5.4	ø11.2	x 1	M4/1Am/H4	3.13	104	2.8
	2					ER2-020L	3.7						
		ER2-020S	7.0	8.4	6.25	132	5.6						
2.5	ER2-025S	F		3.5					5.7	6.8	ø11.2	x 1	
3	ER2-030S	E				4.4	5.3	ø10.2	x 2				
5	ER2-050S	F				2.9	3.5	ø11.2	x 2				

Dimensions (mm)

Capacity (t)	Product Code	Headroom C	D	a (MFC)	b (MFC)	d (MFC)	e (MFC)	f (MFC)	g	h	i (MFC)
125kg	ER2-001H	350	430	478(564)	321(345)	219(305)	259	260(284)	27	99	93(117)
250kg	ER2-003S			510(593)							
		ER2-003H	370	490	348	242(325)	271(273)	283	27	113	106
500kg	ER2-005L	510(593)									
	ER2-005S	430	550	589(632)	376	291(332)	298(300)	335	31	129	118
1	ER2-010S			598(639)							
1.5	ER2-015S	510	630	646(738)	427	308(397)	338(341)	384.5	34	160.5	137.5
	2	ER2-020L		575							
		ER2-020S	590								
2.5	ER2-025S	625	840	736(826)	445	337(427)	399	437.5		173.5	142.5
3	ER2-030S	785	920	703(782)	427	347(426)	356	397	44	216	82
5	ER2-050S	850		736(826)	445	337(427)	399	439	47	231.5	84.5

Note: Figures in () are data for mechanical brake with friction clutch.

ER2 Dual Speed inverter

With Hook Suspension

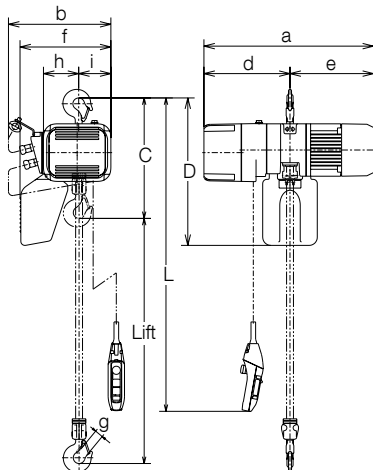

- Standard length of power supply cable is five meters.
- Optional length of lift, push button cord and power supply cable besides standard is available on your request.
- Extending the load chain is prohibited with additional links.
- Steel chain containers are available as option as shown in Section of "Chain Containers" if your lift is more than capacity of the standard container volume.
- Lifting Speed in catalogue is at the rated load. It may vary depending on actual load.



PAVLÍNEK[®]
VÁZACÍ PROSTŘEDKY

EMAIL: OBCHOD@PAVLINEK.CZ
TEL: +420 595 693 911
ŠALOUNOVA 746/31, OSTRAVA VÍTKOVICE
IČ: 25358511 DIČ: CZ25358511



Specifications

Capacity (t)	Product Code	Hoist Body	Standard Lift (m)	Lifting Motor		Lifting Speed (m/min)*			Load Chain		Classification ISO/FEM/ASME	Test Load (t)	Net Weight (kg)	Additional Weight per 1m Lift (kg)			
				Output (kW)	Rating (%ED)	50/60Hz		Diameter (mm)	Chain Falls								
						High	Low										
125kg	ER2-001IH	B		0.56		Preset	2.8	16.6	2.3	1.4	1.8	0.43	x 1	M6/3m/H4 (M5/2m/H4)	156kg	27	0.42
250kg	ER2-003IS					Adjustable	1.8										
	ER2-003IH	C		0.9		Preset	2.6	15.7	1.3	0.4	0.8	0.6	x 1		625kg	32	0.81
500kg	ER2-005IL					Adjustable	0.7										
	ER2-005IS	D	3	0.56	40/20	Preset	1.4	8.5	0.7	0.4	1.4	0.7	x 1		1.25	45	1.33
1	ER2-010IL					Adjustable	0.3										
	ER2-010IS	E		1.8		Preset	1.4	8.2	0.7	0.4	0.9	0.4	x 1		1.88	72	
1.5	ER2-015IS					Adjustable	0.4										
	ER2-020IL	F		3.5		Preset	0.7	4.3	0.4	0.4	0.7	0.4	x 1		2.5	73	2.3
2	ER2-020IS					Adjustable	0.4										
	ER2-025IS	E		3.5		Preset	1.1	6.6	0.6	0.9	0.4	0.6	x 1		3.13	100	2.8
2.5	ER2-025IS					Adjustable	0.6										
	ER2-030IS	F		3.5		Preset	0.9	5.2	0.4	0.6	0.4	0.6	x 2		3.75	105	4.7
3	ER2-030IS					Adjustable	0.4										
	ER2-050IS					Preset	0.6	3.3	0.3	0.6	0.3	0.6	x 2		6.25	128	5.6
5	ER2-050IS	Adjustable	0.3														

Note: The high speed is preset to the maximum speed in KITO factory. The speeds are adjustable between High and Low. Figures in () are data for mechanical brake with friction clutch.

Dimensions (mm)

Capacity (t)	Product Code	Headroom C	D	a (MFC)	b	d (MFC)	e (MFC)	f	g	h	i
125kg	ER2-001IH	350	430	535(564)	345	276(305)	259	284	27	99	117
250kg	ER2-003IS			568(593)							
	ER2-003IH	370	490	571(598)	348	300(325)	271(273)	283	27	113	106
500kg	ER2-005IL			568(593)							
	ER2-005IS	430	550	614(632)	376	316(332)	298(300)	335	31	129	118
1	ER2-010IL			623(639)							
	ER2-010IS	510	630	710(737)	427	372(397)	338(340)	384.5	34	160.5	137.5
1.5	ER2-015IS			767(782)							
	ER2-020IL	575	630	710(737)	427	372(397)	338(340)	384.5	34	160.5	137.5
2	ER2-020IS			767(782)							
	ER2-025IS	590	630	710(737)	427	372(397)	338(340)	384.5	34	160.5	137.5
2.5	ER2-025IS			767(782)							
	ER2-030IS	625	840	800(826)	445	401(427)	399	437.5	44	216	82
3	ER2-030IS			767(782)							
	ER2-050IS	785	920	800(826)	445	401(427)	399	439	47	231.5	84.5
5	ER2-050IS			800(826)							

Note: Figures in () are data for mechanical brake with friction clutch.

ER2M Single Lifting - Single Traversing Speed

With Motorized Trolley

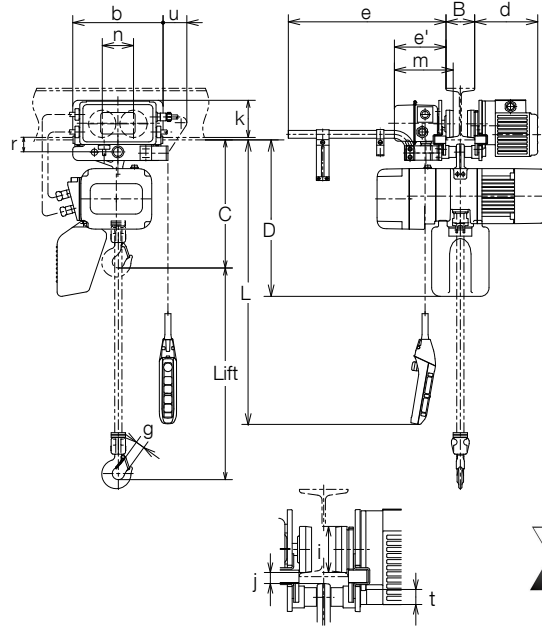

- Standard length of power supply cable is ten meters.
- Optional length of lift, push button cord and power supply cable besides standard is available on your request.
- Extending the load chain is prohibited with additional links.
- Steel chain containers are available as option as shown in Section of "Chain Containers" if your lift is more than capacity of the standard container volume.
- Single Lifting - Dual Traversing is also available.

PAVLÍNEK VÁZACÍ PROSTŘEDKY
 EMAIL: OBCHOD@PAVLINEK.CZ
 TEL: +420 595 693 911
 ŠALOUNOVA 746/31, OSTRAVA VITKOVICE
 IČ: 25350511 DIČ: CZ25350511

Specifications

Capacity (t)	Product Code	Hoist Body	Standard Lift (m)	ER2						MR2						Test Load (t)	Net Weight (kg)	Additional Weight per 1m Lift (kg)		
				Lifting Motor		Lifting Speed (m/min)		Load Chain		Classification ISO/FEM /ASME	Traversing Motor		Traversing Speed (m/min)		Flange Width B (mm)				Min. Radius Curve (mm)	
				Output (kW)	Rating (%ED)	50Hz	60Hz	Diameter (mm)	Chain Falls		Output (kW)	Rating (%ED)	50Hz	60Hz	Standard					Option W30 (305mm)
125kg	ER2M001H-S/L	B	3	0.56	60	14.1	16.9	ø4.3 x 1	M5/2m /H4	0.4	40	20 (10)	24 (12)	58 to 153	154 to 305	800	156kg	58	0.42	
250kg	ER2M003S-S/L					9.1	10.9										625kg			64
	ER2M003H-S/L	0.9	13.4	16.1	68															
500kg	ER2M005L-S/L	C	3	0.56	60	3.8	4.6	ø6.0 x 1	M4/1Am /H4	0.75	40	20 (10)	24 (12)	82 to 178	179 to 305	1000	625kg	64	0.81	
	ER2M005S-S/L					0.9	7.3										8.8	68		
1	ER2M010L-S/L	D	3	0.9	60	3.5	4.2	ø7.7 x 1	M4/1Am /H4	0.75	40	20 (10)	24 (12)	82 to 178	179 to 305	1000	1.25	77	1.33	
	ER2M010S-S/L					7.1	8.5										84			
1.5	ER2M015S-S/L	E	3	1.8	60	4.5	5.4	ø10.2 x 1	M4/1Am /H4	0.75	40	20 (10)	24 (12)	82 to 178	179 to 305	1000	1.88	110	2.3	
	2					ER2M020L-S/L	3.7										4.4	111		
ER2M020S-S/L		7.0	8.4	129																
2.5	ER2M025S-S/L	F	3	3.5	60	5.7	6.8	ø11.2 x 1	M4/1Am /H4	0.75	40	20 (10)	24 (12)	82 to 178	179 to 305	1000	3.13	152	2.8	
3	ER2M030S-S/L	E	3	3.5	60	4.4	5.3	ø10.2 x 2	M4/1Am /H4	0.75	40	20 (10)	24 (12)	82 to 178	179 to 305	1000	3.75	155	4.7	
5	ER2M050S-S/L	F	3	3.5	60	2.9	3.5	ø11.2 x 2	M4/1Am /H4	0.75	40	20 (10)	24 (12)	100 to 178	1800	6.25	202	5.6		

Note: The bracketed figures in Traversing Speed are low speed. The minimum radius curve may depend on flange width. For further information, contact the nearest KITO dealer.

Dimensions (mm)

Capacity (t)	Product Code	Headroom C	D	b	d	e	e'	g	i	j	k	m	n	r	t	u
125kg	ER2M001H-S/L	375	450													
250kg	ER2M003S-S/L															
	ER2M003H-S/L							27								
500kg	ER2M005L-S/L	395	510	315	220	515	179		95	22	130	205	109	51	31	83
	ER2M005S-S/L															
1	ER2M010L-S/L	435	550						31							
	ER2M010S-S/L															
1.5	ER2M015S-S/L	505							34							
	2															
ER2M020S-S/L		585							39							
2.5	ER2M025S-S/L	620	830													
3	ER2M030S-S/L	765	900	340	226	521	186		125	29	131	215	132	68	43	70
5	ER2M050S-S/L	840	910	400	281	528	192	47	140	44	145	233	150	86	54	56

ER2M Dual Lifting inverter - Dual Traversing Speed inverter

With Motorized Trolley

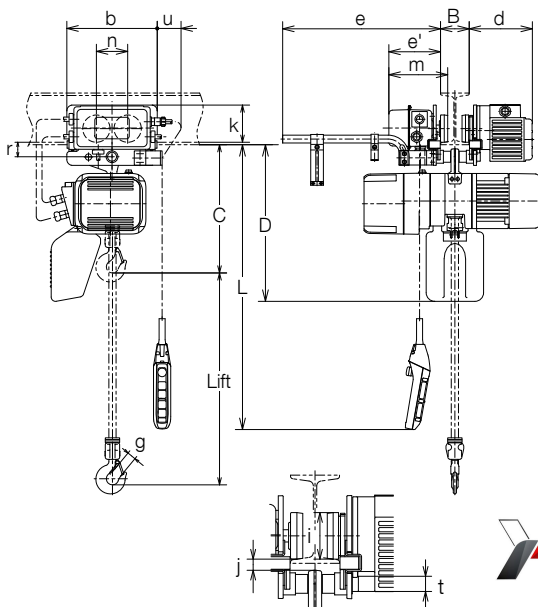

- Standard length of power supply cable is ten meters.
- Optional length of lift, push button cord and power supply cable besides standard is available on your request.
- Extending the load chain is prohibited with additional links.
- Steel chain containers are available as option as shown in Section of "Chain Containers" if your lift is more than capacity of the standard container volume.
- Lifting Speed in catalogue is at the rated load. It may vary depending on actual load.



Specifications

Capacity (t)	Product Code	Hoist Body	Standard Lift (m)	ER2						MR2				Test Load (t)	Net Weight (kg)	Additional Weight per 1m Lift (kg)					
				Lifting Motor		Lifting Speed (m/min)*		Load Chain	Classification ISO/FEM /ASME	Traversing Motor		Traversing Speed* (m/min)					Flange Width B (mm)		Min. Radius Curve (mm)		
				Output (kW)	Rating (%ED)	50/60Hz High	50/60Hz Low			Diameter (mm) x Chain Falls	Output (kW)	Rating (%ED)	50/60Hz High				50/60Hz Low	Standard		Option W30 (305mm)	
125kg	ER2M001IH-IS	B	3	0.56	40/20	Preset	16.6	2.8	ø4.3 x 1	M6/3m /H4 (M5/2m) /H4	0.4	27/13	Preset	24	4	58 to 153	154 to 305	800	156kg	59	0.42
250kg	ER2M003IS-IS					Adjustable	10.8	1.8											Preset		
250kg	ER2M003IH-IS	C	3	0.9	40/20	Preset	4.5	0.8	ø6.0 x 1	M5/2m /H4	0.4	27/13	Preset	24	4	58 to 153	154 to 305	800	313kg	69	0.81
500kg	ER2M005IL-IS					Adjustable	15.7	1.3											Preset		
500kg	ER2M005IS-IS	D	3	0.9	40/20	Preset	4.2	0.7	ø7.7 x 1	M5/2m /H4	0.4	27/13	Preset	24	4	58 to 153	154 to 305	800	625kg	69	0.81
1	ER2M010IL-IS					Adjustable	8.2	1.4											Preset		
1	ER2M010IS-IS	E	3	1.8	40/20	Preset	8.2	1.4	ø10.2 x 1	M4/1Am /H4	0.75	27/13	Preset	24	2.4	82 to 178	179 to 305	1000	1.25	77	1.33
1.5	ER2M015IS-IS					Adjustable	5.3	0.9											Preset		
2	ER2M020IL-IS	F	3	3.5	40/20	Preset	4.3	0.7	ø10.2 x 1	M4/1Am /H4	0.75	27/13	Preset	24	2.4	82 to 178	179 to 305	1000	1.88	111	2.3
2	ER2M020IS-IS					Adjustable	4.3	0.7											Preset		
2.5	ER2M025IS-IS	E	3	3.5	40/20	Preset	6.6	1.1	ø11.2 x 1	M4/1Am /H4	0.75	27/13	Preset	24	2.4	82 to 178	179 to 305	1000	2.5	112	2.3
3	ER2M030IS-IS					Adjustable	6.6	1.1											Preset		
3	ER2M030IS-IS	F	3	3.5	40/20	Preset	5.2	0.9	ø10.2 x 2	M4/1Am /H4	0.75	27/13	Preset	24	2.4	82 to 178	179 to 305	1000	1.29	129	2.3
5	ER2M050IS-IS					Adjustable	3.3	0.6											Preset		
5	ER2M050IS-IS	F	3	3.5	40/20	Preset	3.3	0.6	ø11.2 x 2	M4/1Am /H4	0.75	27/13	Preset	24	2.4	100 to 178	1800	1800	6.25	200	5.6
5	ER2M050IS-IS					Adjustable	3.3	0.3											Preset		

Note: The minimum radius curve may depend on flange width. For further information, contact the nearest KITO dealer.
The high speed is preset to the maximum speed in KITO factory. The speeds are adjustable between High and Low.
Figures in () are data for mechanical brake with friction clutch.

Dimensions (mm)

Capacity (t)	Product Code	Headroom C	D	b	d	e	e'	g	i	j	k	m	n	r	t	u
125kg	ER2M001IH-IS	375	450													
250kg	ER2M003IS-IS															
250kg	ER2M003IH-IS	395	510	315	220	515	179	27	95	22	130	205	109	51	31	83
500kg	ER2M005IL-IS															
500kg	ER2M005IS-IS	435	550													
1	ER2M010IL-IS															
1	ER2M010IS-IS	505														
1.5	ER2M015IS-IS															
2	ER2M020IL-IS	570	630	325	225	520	184		110	27	125	212	118	60	36	76
2	ER2M020IS-IS	585						39								
2.5	ER2M025IS-IS	620	830	340	226	521	186		125	29	131	215	132	68	43	70
3	ER2M030IS-IS	765	900					44								
5	ER2M050IS-IS	840	910	400	281	528	192	47	140	44	145	233	150	86	54	56



With Geared Trolley

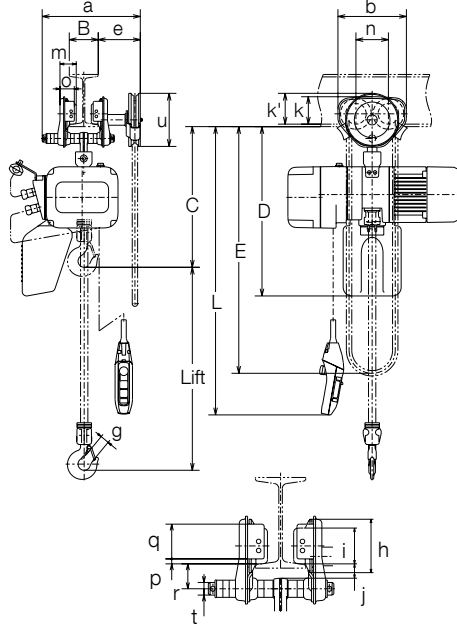

- Standard length of power supply cable is five meters.
- Optional length of lift, push button cord and power supply cable besides standard is available on your request.
- Extending the load chain is prohibited with additional links.
- Steel chain containers are available as option as shown in Section of "Chain Containers" if your lift is more than capacity of the standard container volume.

Specifications

Capacity (t)	Product Code	Hoist Body	Standard Lift (m)	ER2				TSG				Test Load (t)	Net Weight (kg)	Additional Weight per 1m Lift (kg)			
				Lifting Motor		Load Chain		Classification ISO/FEM /ASME	Flange Width B (mm)	Min. Radius Curve (mm)							
				Output (kW)	Rating (%ED)	50Hz	60Hz				Diameter (mm) x Chain Falls				Standard	Option	
125kg	ER2SG001H	B	3	0.56	60	14.1	16.9	ø4.3 x 1	M5/2m /H4	2.8	58 to 127	128 to 203	204 to 305	1300	156kg	40	1.4
250kg	ER2SG003S					9.1	10.9								313kg	50	
	ER2SG003H			0.9		13.4	16.1	ø6.0 x 1	M5/2m /H4	2.8	58 to 127	128 to 203	204 to 305	1300	625kg	46	1.7
500kg	ER2SG005L	C	3	0.56	60	3.8	4.6								7.3	8.8	59
	ER2SG005S							0.9		3.5	4.2	ø7.7 x 1	M4/1Am /H4	3.3	100 to 178	179 to 305	2300
1	ER2SG010L	D	3	1.8	60	7.1	8.5	ø10.2 x 1	M4/1Am /H4	3.3	100 to 178						
	ER2SG010S											0.9		3.5	4.2	ø7.7 x 1	M4/1Am /H4
1.5	ER2SG015S	E	3	1.8	60	4.5	5.4	ø10.2 x 1	M4/1Am /H4	3.3	100 to 178	179 to 305	2300	1.88	89		
	ER2SG020L													0.9		3.7	4.4
2	ER2SG020S			0.9		7.0	8.4	ø10.2 x 1	M4/1Am /H4	3.3	100 to 178	179 to 305	2300	109			
	ER2SG025S	F	3	3.5	60	5.7	6.8							ø11.2 x 1	M4/1Am /H4	3.3	100 to 178
2.5	ER2SG025S							3.5		4.4	5.3	ø10.2 x 2	M4/1Am /H4				
3	ER2SG030S	E	3	3.5	60	2.9	3.5	ø11.2 x 2	M4/1Am /H4	3.3	100 to 178			179 to 305	2300	6.25	188
	ER2SG050S											3.5				2.9	3.5
5	ER2SG050S	F	3	3.5	60	2.9	3.5	ø11.2 x 2	M4/1Am /H4	3.3	100 to 178	179 to 305	2300				

Dimensions (mm)

Capacity (t)	Product Code	Headroom C	D	a	b	e	g	h	i	j	k	k'	m	n	o	p	q	r	t	u
125kg	ER2SG001H	415	490																	
250kg	ER2SG003S																			
	ER2SG003H						27													
500kg	ER2SG005L	435	550	345	236	152		106	71	28	95	107	56	112	50		69	50	25	
	ER2SG005S																			
1	ER2SG010L	470	590																	
	ER2SG010S								31									10		
1.5	ER2SG015S	570																		
	ER2SG020L	635	690	385	280	154		127	85	34	112	109	71	131	63		83	62	32	
	ER2SG020S	650																		
2.5	ER2SG025S	680	890																	
	ER2SG030S	780	910	398	324	157		148	100	36	134	115	80	152	74		102	68	36	
3	ER2SG030S	780			44															
5	ER2SG050S	840		401	400	156		169	118	46	144	131	81	178	70		104	88	54	



With Geared Trolley

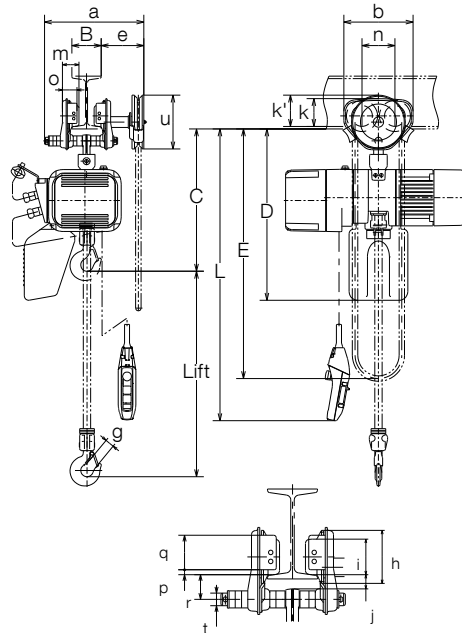

- Standard length of power supply cable is five meters.
- Optional length of lift, push button cord and power supply cable besides standard is available on your request.
- Extending the load chain is prohibited with additional links.
- Steel chain containers are available as option as shown in Section of "Chain Containers" if your lift is more than capacity of the standard container volume.
- Lifting Speed in catalogue is at the rated load. It may vary depending on actual load.

Specifications

Capacity (t)	Product Code	Hoist Body	Standard Lift (m)	Lifting Motor		Lifting Speed (m/min)*		Load Chain	Classification ISO/FEM /ASME	Folded Hand Chain Length E (m)	Flange Width B (mm)			Min. Radius Curve (mm)	Test Load (t)	Net Weight (kg)	Additional Weight per 1m Lift (kg)
				Output (kW)	Rating (%ED)	High	Low				Diameter (mm) x Chain Falls	Standard	Option				
						50/60Hz		W20 (203mm)	W30 (305mm)								
125kg	ER2SG001IH	B		0.56		Preset	16.6	2.8	ø4.3 x 1	M6/3m /H4				156kg	40	1.4	
	ER2SG003IS					Adjustable	10.8	1.4									Preset
250kg	ER2SG003IH	C		0.9		Preset	15.7	2.6	ø6.0 x 1		58 to 127	128 to 203	204 to 305	1300	625kg	45	1.7
	ER2SG005IS					Adjustable	4.5	0.8									
500kg	ER2SG005IL	D	3	40/20	0.9	Preset	8.2	1.4	ø7.7 x 1	M5/2m /H4				1.25	64	2.3	
	ER2SG010IS					Adjustable	4.2	0.3									Preset
1	ER2SG010IL	E		1.8		Preset	5.3	0.9	ø10.2 x 1					1500	90	3.2	
	ER2SG015IS					Adjustable	4.3	0.4									Preset
2	ER2SG020IL	F		3.5		Preset	8.2	0.7	ø11.2 x 1	M4/1Am /H4	82 to 153			1700	3.13	128	3.7
	ER2SG020IS					Adjustable	4.3	0.4									
2.5	ER2SG025IS	E		1.8		Preset	5.2	0.4	ø10.2 x 2					2300	6.25	184	6.5
	ER2SG030IS					Adjustable	3.3	0.6									
3	ER2SG030IS	F		3.5		Preset	3.3	0.3	ø11.2 x 2					2300	6.25	184	6.5
	ER2SG050IS					Adjustable	3.3	0.3									

Note: The high speed is preset to the maximum speed in KITO factory. The speeds are adjustable between High and Low.

Dimensions (mm)

Capacity (t)	Product Code	Headroom C	D	a	b	e	g	h	i	j	k	k'	m	n	o	p	q	r	t	u
125kg	ER2SG001IH	415	490																	
250kg	ER2SG003IS			ER2SG003IH				27												
500kg	ER2SG005IL	435	550	345	236	152		106	71	28	95	107	56	112	50		69	50	25	
	ER2SG005IS																			
1	ER2SG010IL	470	590																	
	ER2SG010IS							31									10			
1.5	ER2SG015IS	570																		
2	ER2SG020IL	635	690	385	280	154		127	85	34	112	109	71	131	63		83	62	32	
	ER2SG020IS	650																		
2.5	ER2SG025IS	680	890																	
3	ER2SG030IS	780			398	324	157		148	100	36	134	115	80	152	74		102	68	36
5	ER2SG050IS	840	910	401	400	156		169	118	46	144	131	81	178	70		104	88	54	



With Plain Trolley

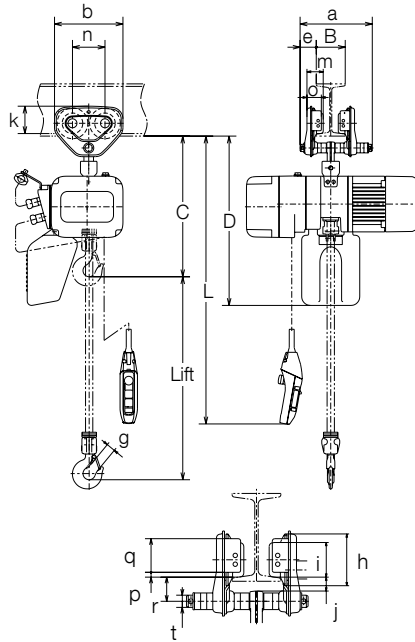

- Standard length of power supply cable is five meters.
- Optional length of lift, push button cord and power supply cable besides standard is available on your request.
- Extending the load chain is prohibited with additional links.
- Steel chain containers are available as option as shown in Section of "Chain Containers" if your lift is more than capacity of the standard container volume.
- The hoist direction to a beam for 3 t or 5 t is different 90 degrees.

Specifications

Capacity (t)	Product Code	Hoist Body	Standard Lift (m)	ER2					TSP			Test Load (t)	Net Weight (kg)	Additional Weight per 1m Lift (kg)	
				Lifting Motor		Lifting Speed (m/min)		Load Chain	Classification ISO/FEM/ASME	Flange Width B (mm)					Min. Radius Curve (mm)
				Output (kW)	Rating (%ED)	50Hz	60Hz			Standard	Option				
125kg	ER2SP001H	B	3	0.56	60	14.1	16.9	ø4.3 x 1	M5/2m/H4	50 to 102	103 to 203	1100	156kg	32	0.42
250kg	ER2SP003S					9.1	10.9						313kg	42	
	ER2SP003H	C	3	0.9	60	13.4	16.1	ø6.0 x 1	M5/2m/H4	50 to 102	103 to 203	1100	625kg	38	0.81
500kg	ER2SP005L					7.3	8.8						42		
	ER2SP005S	D	3	0.9	60	3.5	4.2	ø7.7 x 1	M5/2m/H4	58 to 127	128 to 203	1300	1.25	55	1.33
1	ER2SP010L					7.1	8.5						62		
	ER2SP010S	E	3	1.8	60	3.7	4.4	ø10.2 x 1	M4/1Am/H4	82 to 153	154 to 305	1500	1.88	85	2.3
1.5	ER2SP015S					7.0	8.4						2.5	105	
	ER2SP020L	F	3	3.5	60	5.7	6.8	ø11.2 x 1	M4/1Am/H4	82 to 153	154 to 305	1700	3.13	128	2.8
2	ER2SP020S					4.4	5.3						ø10.2 x 2	3.75	130
	ER2SP020S	E	3	3.5	60	2.9	3.5	ø11.2 x 2	M4/1Am/H4	100 to 178	179 to 305	2300	6.25	182	5.6
2.5	ER2SP025S					2.9	3.5						ø11.2 x 2	6.25	182
3	ER2SP030S	F	3	3.5	60	2.9	3.5	ø11.2 x 2	M4/1Am/H4	100 to 178	179 to 305	2300	6.25	182	5.6

Dimensions (mm)

Capacity (t)	Product Code	Headroom C	D	a	b	e	g	h	i	j	k	m	n	o	p	q	r	t
125kg	ER2SP001H	395	470															
250kg	ER2SP003S																	
	ER2SP003H	415	530	204	182	46	27	82	60	21	76	47.5	84	42		54	38	22
500kg	ER2SP005L																	
	ER2SP005S	470	590	249	236	56	31	106	71	28	95	56	112	50	10	69	50	25
1	ER2SP010L																	
	ER2SP010S	570	690					34										
1.5	ER2SP015S																	
	ER2SP020L	635	690	300	280	69		127	85	34	112	71	131	63		83	62	32
2	ER2SP020S	650	690					39										
	ER2SP025S	680	890															
2.5	ER2SP025S	680	890	320	324	79		148	100	36	134	80	152	74		102	68	36
3	ER2SP030S	780	910					44										
	ER2SP030S	780	910															
5	ER2SP050S	840	910	297	400	53	47	169	118	46	144	81	178	70		104	88	54



With Plain Trolley

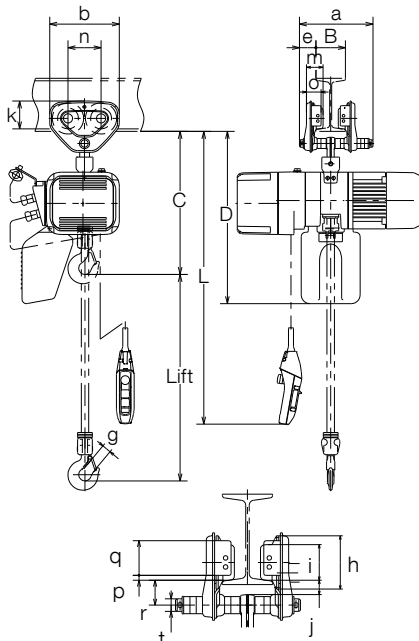

- Standard length of power supply cable is five meters.
- Optional length of lift, push button cord and power supply cable besides standard is available on your request.
- Extending the load chain is prohibited with additional links.
- Steel chain containers are available as option as shown in Section of "Chain Containers" if your lift is more than capacity of the standard container volume.
- The hoist direction to a beam for 3 t or 5 t is different 90 degrees.
- Lifting Speed in catalogue is at the rated load. It may vary depending on actual load.

Specifications

Capacity (t)	Product Code	Hoist Body	Standard Lift (m)	Lifting Motor		Lifting Speed (m/min)*		Load Chain	Classification ISO/FEM /ASME	Flange Width B (mm)			Min. Radius Curve (mm)	Test Load (t)	Net Weight (kg)	Additional Weight per 1m Lift (kg)
				Output (kW)	Rating (%ED)	50/60Hz				Diameter (mm) x Chain Falls	Standard	Option				
						High	Low	W20 (203mm)	W30 (305mm)							
125kg	ER2SP001IH	B	3	0.56	40/20	Preset	16.6	2.8	ø4.3 x 1	M6/3m /H4	50 to 102	103 to 203	1100	156kg	32	0.42
	ER2SP003IS					Adjustable	10.8	1.4								
250kg	ER2SP003IH	C	3	0.9	40/20	Preset	15.7	2.6	ø6.0 x 1	M5/2m /H4	58 to 127	128 to 203	1300	313kg	41	
	ER2SP005IS					Adjustable	4.5	0.8								
500kg	ER2SP005IL	D	3	0.56	40/20	Preset	8.5	1.4	ø7.7 x 1	M4/1Am /H4	82 to 153	154 to 305	1700	625kg	37	0.81
	ER2SP010IS					Adjustable	8.2	0.4								
1	ER2SP010IL	E	3	1.8	40/20	Preset	5.3	0.7	ø10.2 x 1	M4/1Am /H4	100 to 178	179 to 305	2300	1.88	85	
	ER2SP015IS					Adjustable	4.3	0.3								
1.5	ER2SP020IL	F	3	1.8	40/20	Preset	8.2	1.4	ø11.2 x 1	M4/1Am /H4	100 to 178	179 to 305	2300	2.5	86	2.3
	ER2SP020IS					Adjustable	5.2	0.4								
2	ER2SP025IS	F	3	1.8	40/20	Preset	3.3	0.6	ø10.2 x 2	M4/1Am /H4	100 to 178	179 to 305	2300	3.13	124	2.8
	ER2SP030IS					Adjustable	3.3	0.3								
2.5	ER2SP025IS	F	3	3.5	40/20	Preset	5.2	0.9	ø11.2 x 2	M4/1Am /H4	100 to 178	179 to 305	2300	3.75	128	4.7
	ER2SP050IS					Adjustable	3.3	0.3								

Note: The high speed is preset to the maximum speed in KITO factory. The speeds are adjustable between High and Low.

Dimensions (mm)

Capacity (t)	Product Code	Headroom C	D	a	b	e	g	h	i	j	k	m	n	o	p	q	r	t
125kg	ER2SP001IH	395	470															
250kg	ER2SP003IS					204	182	46	27	82	60	21	76	47.5	84	42		54
500kg	ER2SP003IH	415	530															
	ER2SP005IL																	
1	ER2SP005IS	470	590	249	236	56	31	106	71	28	95	56	112	50	10	69	50	25
	ER2SP010IL																	
1.5	ER2SP010IS	570	690				34											
	ER2SP015IS					300	280	69		127	85	34	112	71	131	63		83
2	ER2SP020IL	635	890															
	ER2SP020IS								39									
2.5	ER2SP025IS	780	910	320	324	79		148	100	36	134	80	152	74		102	68	36
3	ER2SP030IS								44									
5	ER2SP050IS	840		297	400	53	47	169	118	46	144	81	178	70		104	88	54

ER2 Dual Speed 500V pole change

With Hook Suspension

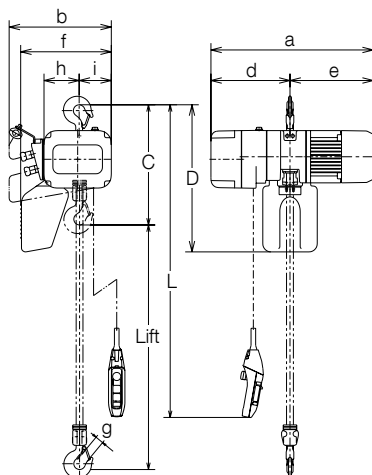

- Standard length of power supply cable is five meters.
- Optional length of lift, push button cord and power supply cable besides standard is available on your request.
- Extending the load chain is prohibited with additional links.
- Steel chain containers are available as option as shown in Section of "Chain Containers" if your lift is more than capacity of the standard container volume.



PAVLÍNEK[®]
VÁZACÍ PROSTŘEDKY

EMAIL: OBCHOD@PAVLINEK.CZ
TEL: +420 595 693 911
ŠALOUNOVA 746/31, OSTRAVA VÍTKOVICE
IČ: 25358511 DIČ: CZ25358511



Specifications

Capacity (t)	Product Code	Hoist Body	Standard Lift (m)	Lifting Motor		Lifting Speed (m/min)	Load Chain		Classification ISO/FEM/ASME	Test Load (t)	Net Weight (kg)	Additional Weight per 1m Lift (kg)
				Output (kW)	Rating (%ED)		50Hz	Diameter (mm) x Chain Falls				
125kg	ER2-001HD	B	3	0.5/0.13	40/20	14.2/3.5	ø4.3 x 1	M5/2m/H4	156kg	31	0.42	
250kg	ER2-003SD					7.2/1.8						
500kg	ER2-005LD	C	3	0.9/0.23	40/20	3.6/0.9	ø6.0 x 1	M5/2m/H4	625kg	39	0.81	
	ER2-005SD					7.1/1.8				43		
1	ER2-010LD	D	3	1.8/0.45	40/20	3.5/0.9	ø7.7 x 1	M5/2m/H4	1.25	56	1.33	
	ER2-010SD					7.2/1.7				58		
1.5	ER2-015SD	E	3	1.8/0.45	40/20	4.8/1.2	ø10.2 x 1	M4/1Am/H4	1.88	74	2.3	
2	ER2-020LD					3.7/0.9				76		
	ER2-020SD	6.9/1.6	97									
2.5	ER2-025SD	F	3	3.5/0.88	40/20	5.5/1.3	ø11.2 x 1	M4/1Am/H4	3.13	108	2.8	
3	ER2-030SD	E	3	3.5/0.88	40/20	4.4/1.0	ø10.2 x 2	M4/1Am/H4	3.75	113	4.7	
						2.8/0.6			ø11.2 x 2	6.25	134	5.6

Dimensions (mm)

Capacity (t)	Product Code	Headroom C	D	a (MFC)	b (MFC)	d (MFC)	e (MFC)	f (MFC)	g	h	i (MFC)
125kg	ER2-001HD	350	430	478 (564)	321 (345)	219 (305)	259	260 (284)	27	99	93 (117)
250kg	ER2-003SD			513 (598)	348	242 (325)	271 (273)	283			27
500kg	ER2-005LD	370	490	533 (616)			376		291 (332)	298 (300)	
	ER2-005SD			589 (632)	324						
1	ER2-010LD	430	550	615 (656)	427	347 (426)	390	384.5	39	160.5	137.5
ER2-010SD	737 (816)										
1.5	ER2-015SD	510	630	646 (737)	445	337 (427)	399	437.5	44	216	82
2	ER2-020LD	575		736 (826)							
	ER2-020SD	590	737 (816)								
2.5	ER2-025SD	625	840	736 (826)	445	337 (427)	399	437.5	44	216	82
3	ER2-030SD	785	920	736 (826)	445	337 (427)	399	439	47	231.5	84.5
5	ER2-050SD	850		736 (826)							

Note: Figures in () are data for mechanical brake with friction clutch.

ER2M Dual Lifting pole change - Dual Traversing Speed **500V** pole change

With Motorized Trolley

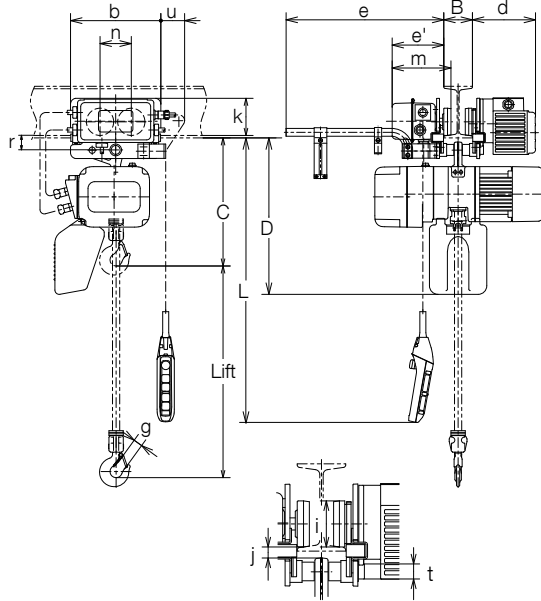

- Standard length of power supply cable is ten meters.
- Optional length of lift, push button cord and power supply cable besides standard is available on your request.
- Extending the load chain is prohibited with additional links.
- Steel chain containers are available as option as shown in Section of "Chain Containers" if your lift is more than capacity of the standard container volume.

Specifications

Capacity (t)	Product Code	Hoist Body	ER2						MR2				Test Load (t)	Net Weight (kg)	Additional Weight per 1m Lift (kg)		
			Standard Lift (m)	Lifting Motor		Lifting Speed (m/min)	Load Chain	Classification ISO/FEM /ASME	Traversing Motor		Traversing Speed (m/min)	Flange Width B (mm)				Min. Radius Curve (mm)	
				Output (kW)	Rating (%ED)				Output (kW)	Rating (%ED)		Standard					Option W30 (305mm)
125kg	ER2M001HD-SD	B	3	0.5/0.13	40/20	14.2/3.5	ø4.3 x 1	M5/2m /H4	0.32/0.08	27/13	20/5	58 to 153	154 to 305	800	156kg	66	0.42
250kg	ER2M003SD-SD					7.2/1.8									625kg		
500kg	ER2M005LD-SD	C	3	0.9/0.23	40/20	3.6/0.9	ø6.0 x 1	M5/2m /H4	0.32/0.08	27/13	20/5	58 to 153	154 to 305	800	74	77	0.81
	ER2M005SD-SD					7.1/1.8									625kg		
1	ER2M010LD-SD	D	3	0.9/0.23	40/20	3.5/0.9	ø7.7 x 1	M5/2m /H4	0.32/0.08	27/13	20/5	58 to 153	154 to 305	800	89	92	1.33
	ER2M010SD-SD					7.2/1.7											
1.5	ER2M015SD-SD	E	3	1.8/0.45	40/20	4.8/1.2	ø10.2 x 1	M4/1Am /H4	0.64/0.16	27/13	20/5	82 to 178	179 to 305	1000	1.88	116	2.3
	ER2M020LD-SD					3.7/0.9									2.5		
2	ER2M020SD-SD	E	3	1.8/0.45	40/20	6.9/1.6	ø10.2 x 1	M4/1Am /H4	0.64/0.16	27/13	20/5	82 to 178	179 to 305	1000	138		
2.5	ER2M025SD-SD	F	3	3.5/0.88	40/20	5.5/1.3	ø11.2 x 1	M4/1Am /H4	0.64/0.16	27/13	20/5	100 to 178	1800	1000	3.13	159	2.8
	ER2M030SD-SD					4.4/1.0									3.75		
5	ER2M050SD-SD	F	3	3.5/0.88	40/20	2.8/0.6	11.2 x 2	M4/1Am /H4	0.64/0.16	27/13	20/5	100 to 178	1800	1800	6.25	208	5.6

Note: The minimum radius curve may depend on flange width. For further information, contact the nearest KITO dealer.

Dimensions (mm)

Capacity (t)	Product Code	Headroom C	D	b	d	e	e'	g	i	j	k	m	n	r	t	u
125kg	ER2M001HD-SD	375	450					27								
250kg	ER2M003SD-SD															
500kg	ER2M005LD-SD	395	510	315	268	515	179		95	22	130	205	109	51	31	83
	ER2M005SD-SD															
1	ER2M010LD-SD	435	550					31								
	ER2M010SD-SD															
1.5	ER2M015SD-SD	505						34								
	ER2M020LD-SD															
2	ER2M020SD-SD	585						39								
2.5	ER2M025SD-SD	620	830						125	29	131	215	132	68	43	70
3	ER2M030SD-SD	765	900	340	274	521	186	44								
5	ER2M050SD-SD	840	910	400	281	528	192	47	140	44	145	233	150	86	54	56



EMAIL: OBCHOD@PAVLINEK.CZ
 TEL: +420 595 693 911
 ŠALOUNOVA 746/31, OSTRAVA VÍTKOVICE
 IČ: 25358511 DIČ: CZ25358511



ER2SG Dual Speed 500V pole change

With Geared Trolley

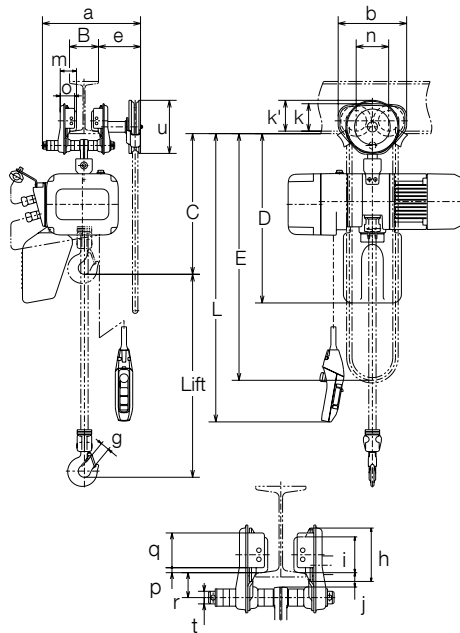

- Standard length of power supply cable is five meters.
- Optional length of lift, push button cord and power supply cable besides standard is available on your request.
- Extending the load chain is prohibited with additional links.
- Steel chain containers are available as option as shown in Section of "Chain Containers" if your lift is more than capacity of the standard container volume.

Specifications

Capacity (t)	Product Code	Hoist Body	Standard Lift (m)	ER2				TSG				Test Load (t)	Net Weight (kg)	Additional Weight per 1m Lift (kg)		
				Lifting Motor		Lifting Speed (m/min)	Load Chain	Classification ISO/FEM /ASME	Folded Hand Chain Length E (m)	Flange Width B (mm)					Min. Radius Curve (mm)	
				Output (kW)	Rating (%ED)					50Hz	Diameter (mm)					Chain Falls
125kg	ER2SG001HD	B	490	0.5/0.13	40/20	14.2/3.5	ø4.3 x 1	M5/2m /H4	2.8	58 to 127	128 to 203	204 to 305	1300	156kg	44	1.4
250kg	ER2SG003SD					7.2/1.8								313kg		
500kg	ER2SG005LD	C	550	0.9/0.23	40/20	3.6/0.9	ø6.0 x 1	M5/2m /H4	2.8	58 to 127	128 to 203	204 to 305	1300	52	56	1.7
	ER2SG005SD					7.1/1.8								625kg		
1	ER2SG010LD	D	590	1.8/0.45	40/20	3.5/0.9	ø7.7 x 1	M4/1Am /H4	3.3	100 to 178	179 to 305	2300	1.25	68	70	2.3
	ER2SG010SD					7.2/1.7							188			
1.5	ER2SG015SD	E	690	3.5/0.88	40/20	4.8/1.2	ø10.2 x 1	M4/1Am /H4	3.3	100 to 178	179 to 305	2300	1.88	91	93	3.2
2	ER2SG020LD					3.7/0.9							2.5			
	ER2SG020SD	6.9/1.6	115													
2.5	ER2SG025SD	F	890	3.5/0.88	40/20	5.5/1.3	ø11.2 x 1	M4/1Am /H4	3.3	100 to 178	179 to 305	2300	3.13	136	140	5.6
3	ER2SG030SD					4.4/1.0							3.75			
5	ER2SG050SD	F	910	2.8/0.6	40/20	ø11.2 x 2	ø11.2 x 2	M4/1Am /H4	3.3	100 to 178	179 to 305	2300	6.25	190	6.5	

Dimensions (mm)

Capacity (t)	Product Code	Headroom C	D	a	b	e	g	h	i	j	k	k'	m	n	o	p	q	r	t	u
125kg	ER2SG001HD	415	490																	
250kg	ER2SG003SD																			
500kg	ER2SG005LD	435	550	345	236	152	27	106	71	28	95	107	56	112	50			69	50	25
	ER2SG005SD																			
1	ER2SG010LD	470	590				31													
	ER2SG010SD																			
1.5	ER2SG015SD	570					34													183
2	ER2SG020LD	635	690	385	280	154	39	127	85	34	112	109	71	131	63			83	62	32
	ER2SG020SD	650																		
2.5	ER2SG025SD	680	890	398	324	157	44	148	100	36	134	115	80	152	74			102	68	36
3	ER2SG030SD	780																		
5	ER2SG050SD	840	910	401	400	156	47	169	118	46	144	131	81	178	70			104	88	54



PAVLÍNEK
VÁZACÍ PROSTŘEDKY

EMAIL: OBCHOD@PAVLINEK.CZ
TEL: +420 595 693 911
ŠALOUNOVA 746/31, OSTRAVA VÍTKOVICE
IČ: 25358511 DIČ: CZ25358511



ER2SP Dual Speed 500V pole change

With Plain Trolley

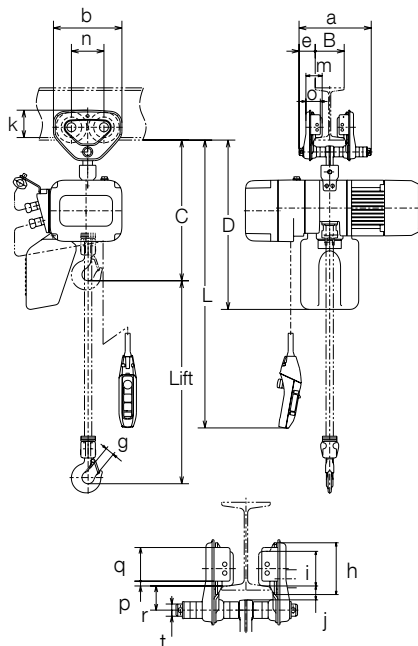

- Standard length of power supply cable is five meters.
- Optional length of lift, push button cord and power supply cable besides standard is available on your request.
- Extending the load chain is prohibited with additional links.
- Steel chain containers are available as option as shown in Section of "Chain Containers" if your lift is more than capacity of the standard container volume.
- The hoist direction to a beam for 3 t or 5 t is different 90 degrees.

Specifications

Capacity (t)	Product Code	Hoist Body	ER2						TSP			Test Load (t)	Net Weight (kg)	Additional Weight per 1m Lift (kg)								
			Standard Lift (m)	Lifting Motor		Lifting Speed (m/min)	Load Chain		Flange Width B (mm)						Min. Radius Curve (mm)							
				Output (kW)	Rating (%ED)		50Hz	Diameter (mm)	Chain Falls	Classification ISO/FEM /ASME	Standard					Option						
125kg	ER2SP001HD	B		0.5/0.13		14.2/3.5	ø4.3 x 1												156kg	36	0.42	
250kg	ER2SP003SD					7.2/1.8													50 to 102			103 to 203
500kg	ER2SP005LD	C		0.9/0.23		3.6/0.9	ø6.0 x 1	M5/2m /H4											625kg	44	0.81	
	ER2SP005SD					7.1/1.8													204 to 305	48		
1	ER2SP010LD	D	3		40/20	3.5/0.9	ø7.7 x 1												66	1.33		
	ER2SP010SD					7.2/1.7													58 to 127		128 to 203	1300
1.5	ER2SP015SD			1.8/0.45		4.8/1.2													1.88	87		
2	ER2SP020LD	E				3.7/0.9	ø10.2 x 1												2.5	89	2.3	
	ER2SP020SD					6.9/1.6													82 to 153	154 to 305		111
2.5	ER2SP025SD	F		3.5/0.88		5.5/1.3	ø11.2 x 1	M4/1Am /H4											1700	3.13	132	2.8
3	ER2SP030SD	E				4.4/1.0	ø10.2 x 2														3.75	136
5	ER2SP050SD	F				2.8/0.6	ø11.2 x 2													6.25	184	5.6

Dimensions (mm)

Capacity (t)	Product Code	Headroom C	D	a	b	e	g	h	i	j	k	m	n	o	p	q	r	t
125kg	ER2SP001HD	395	470															
250kg	ER2SP003SD			204	182	46	27	82	60	21	76	47.5	84	42			54	38
500kg	ER2SP005LD	415	530															
	ER2SP005SD																	
1	ER2SP010LD	470	590	249	236	56	31	106	71	28	95	56	112	50	10	69	50	25
	ER2SP010SD																	
1.5	ER2SP015SD	570					34											
2	ER2SP020LD	635	690	300	280	69	39	127	85	34	122	71	131	63		83	62	32
	ER2SP020SD	650																
2.5	ER2SP025SD	680	890															
3	ER2SP030SD	780	910	320	324	79	44	148	100	36	134	80	152	74		102	68	36
5	ER2SP050SD	840		297	400	53		47	169	118	46	144	81	178		70		104



PAVLÍNEK[®]
VÁZACÍ PROSTŘEDKY

EMAIL: OBCHOD@PAVLINEK.CZ
TEL: +420 595 693 911
ŠALOUNOVA 746/31, OSTRAVA VÍTKOVICE
IČ: 25358511 DIČ: CZ25358511



CDER2 Cylindrical Control Dual/Single Speed

With Hook Suspension



Dual Speed

Single Speed

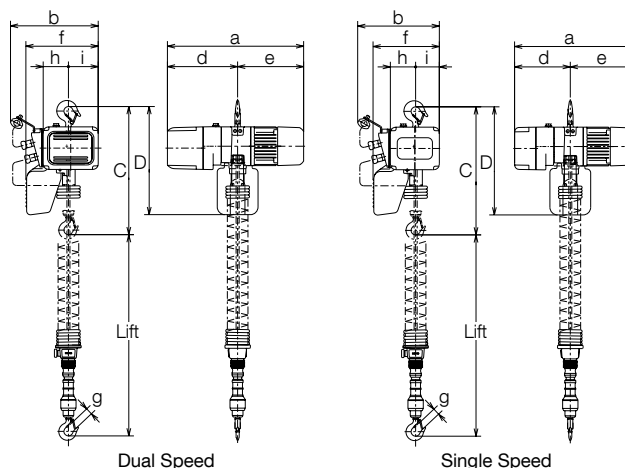

Dual Speed

Single Speed

- Standard length of power supply cable is five meters.
- Length of lift, push button cord and power supply cable is standard only available.
- Extending the load chain is prohibited with additional links.
- Plastic chain container is provided only.

Specifications

Capacity (t)	Product Code	Hoist Body	Standard Lift (m)	Lifting Motor		Lifting Speed (m/min)*		Load Chain		Classification ISO/FEM/ASME	Test Load (kg)	Net Weight (kg)	Additional Weight per 1m Lift (kg)
				Output (kW)	Rating (%ED)	50/60Hz		Diameter (mm)	Chain Falls				
						High	Low						
Dual	125kg ER2C001IH	B	1.8	0.56	40/20	Preset	16.6	2.8	ø4.3 x 1	M6/3m/H4 (M5/2m/H4)	156	28	0.42
						Adjustable	10.8	1.4					
	250kg ER2C003IS					Preset	10.8	1.8			313		
						Adjustable	10.8	0.9					

Note: The high speed is preset to the maximum speed in KITO factory. The speeds are adjustable between High and Low. Figures in () are data for mechanical brake with friction clutch.

500V

Capacity (t)	Product Code	Hoist Body	Standard Lift (m)	Lifting Motor		Lifting Speed (m/min)		Load Chain		Classification ISO/FEM/ASME	Test Load (kg)	Net Weight (kg)	Additional Weight per 1m Lift (kg)
				Output (kW)	Rating (%ED)	50Hz		Diameter (mm)	Chain Falls				
						High	Low						
Dual	125kg ER2C001HD	B	1.8	0.5/0.13	40/20	14.2/3.5		ø4.3 x 1	M5/2m/H4	156	33	0.42	
	250kg ER2C003SD					7.2/1.8							313

Capacity (t)	Product Code	Hoist Body	Standard Lift (m)	Lifting Motor		Lifting Speed (m/min)		Load Chain		Classification ISO/FEM/ASME	Test Load (kg)	Net Weight (kg)	Additional Weight per 1m Lift (kg)
				Output (kW)	Rating (%ED)	50Hz	60Hz	Diameter (mm)	Chain Falls				
						High	Low						
Single	125kg ER2C001H	B	1.8	0.56	60	14.1	16.9	ø4.3 x 1	M5/2m/H4	156	29	0.42	
	250kg ER2C003S					9.1	10.9						313

Dimensions (mm)

Capacity (t)	Product Code	Headroom C	D	a (MFC)	b (MFC)	d (MFC)	e	f (MFC)	g	h	i (MFC)
125kg	ER2C001IH	1010	430	535(564)	345	276(305)	259	284	27	99	117
250kg	ER2C003IS			478(564)	321(345)	219(305)		260(284)			
125kg	ER2C001HD	1010	430	478(564)	321(345)	219(305)	259	260(284)	27	99	117
250kg	ER2C003SD			478(564)	321(345)	219(305)		260(284)			
125kg	ER2C001H	1010	430	478(564)	321(345)	219(305)	259	260(284)	27	99	117
250kg	ER2C003S			478(564)	321(345)	219(305)		260(284)			

Note: Figures in () are data for mechanical brake with friction clutch.



PAVLÍNEK
VÁZACÍ PROSTŘEDKY

EMAIL: OBCHOD@PAVLINEK.CZ
TEL: +420 595 693 911
ŠALOUNOVA 746/31, OSTRAVA VÍTKOVICE
IČ: 25358511 DIČ: CZ25358511



ER2 Large Capacity

With Hook Suspension

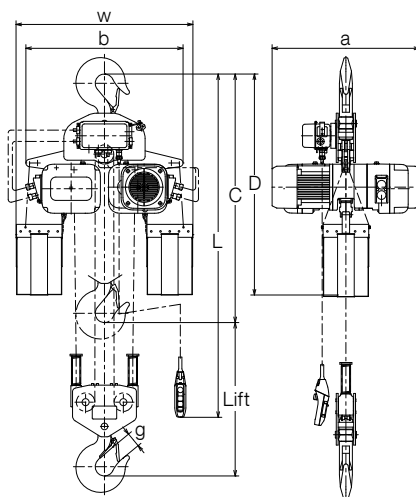

- Standard length of power supply cable is ten meters.
- Optional length of lift, push button cord and power supply cable besides standard is available on your request.
- Extending the load chain is prohibited with additional links.
- Steel chain containers are available as option as shown in Section of "Chain Containers" if your lift is more than capacity of the standard container volume.

Specifications

Capacity (t)	Product Code	Hoist Body	Standard Lift (m)	Lifting Motor		Lifting Speed (m/min)		Load Chain		Classification ISO/FEM/ASME	Test Load (t)	Net Weight (kg)	Additional Weight per 1m Lift (kg)
				Output (kW)	Rating (%ED)	50Hz	60Hz	Diameter (mm)	Chain Falls				
10	ER2-100S	F	3	3.5x2	60	2.9	3.5	ø11.2	x 4	M4/1Am/H4	12.5	303	11
15	ER2-150S					1.9	2.3	ø11.2	x 6		18.8	404	17
20	ER2-200S					1.4	1.7	ø11.2	x 8		25	476	22

Dimensions (mm)

Capacity (t)	Product Code	Headroom C	D	a (MFC)	b	w	g
10	ER2-100S	1370	1210	798	849	956	80
15	ER2-150S	1595	1520	(853)	1022	1129	86
20	ER2-200S	1710	1600		1198	1305	102

Note: Figures in () are data for mechanical brake with friction clutch.



PAVLÍNEK[®]
VÁZACÍ PROSTŘEDKY

EMAIL: OBCHOD@PAVLINEK.CZ
TEL: +420 595 693 911
ŠALOUNOVA 746/31, OSTRAVA VÍTKOVICE
IČ: 25358511 DIČ: CZ25358511



ER2M Large Capacity

With Motorized Trolley

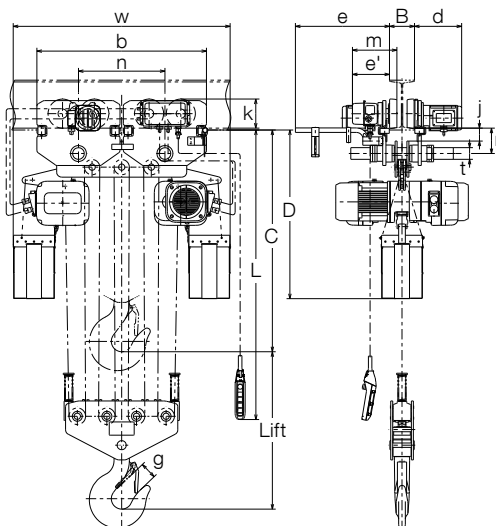

- Standard length of power supply cable is ten meters.
- Optional length of lift, push button cord and power supply cable besides standard is available on your request.
- Extending the load chain is prohibited with additional links.
- Steel chain containers are available as option as shown in Section of "Chain Containers" if your lift is more than capacity of the standard container volume.

Specifications

Capacity (t)	Product Code	ER2							MR2						Test Load (t)	Net Weight (kg)	Additional Weight per 1m Lift (kg)		
		Hoist Body	Standard Lift (m)	Lifting Motor		Lifting Speed (m/min)		Load Chain Diameter (mm) x Chain Falls	Classification ISO/FEM /ASME	Traversing Motor		Traversing Speed (m/min)		Flange Width B (mm)				Min. Radius Curve (mm)	
				Output (kW)	Rating (%ED)	50Hz	60Hz			Output (kW)	Rating (%ED)	50Hz	60Hz	Standard					Option W30 (305mm)
7.5	ER2M075S-L	F	3	3.5	60	1.9	2.3	ø11.2 x 3	M4/1Am /H4	0.75	40	10	12	150 to 220	221 to 305	2500	9.4	283	8.4
10	ER2M100L-L					1.4	1.7	ø11.2 x 4									12.5	378	
	ER2M100S-L			2.9	3.5	ø11.2 x 6	399			11									
15	ER2M150S-L			3.5x2	1.9			2.3			ø11.2 x 6	∞	18.8	571	17				
20	ER2M200S-L	1.4	1.7	ø11.2 x 8	25	628	22												

Note: Trolley wheels for tapered I-beam are provided as standard. The wheels for flat flange beam are also available so make a request in advance if necessary. The minimum radius curve for 7.5t and 10t may depend on flange width. For further information, contact the nearest KITO dealer.

Dimensions (mm)

Capacity (t)	Product Code	Headroom C	D	b	d	e	e'	g	j	k	m	n	r	t	w
7.5	ER2M075S-L	1165	1230	500	284	531	223	61	87	175	268	191	153	70	672
10	ER2M100L-L	1180	1210					80	77						1129
	ER2M100S-L		1020	86	82	1305									
15	ER2M150S-L	1310	1230				1020	102	77	520					
20	ER2M200S-L	1345													



PAVLÍNEK[®]
VÁZACÍ PROSTŘEDKY

EMAIL: OBCHOD@PAVLINEK.CZ
TEL: +420 595 693 911
ŠALOUNOVA 746/31, OSTRAVA VÍTKOVICE
IČ: 25358511 DIČ: CZ25358511



ER2SG Large Capacity

With Geared Trolley

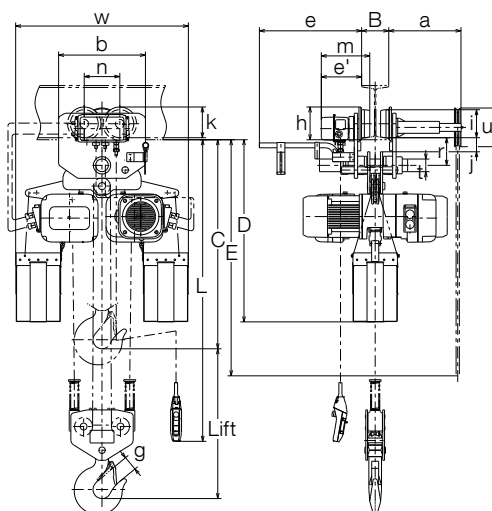

- Standard length of power supply cable is ten meters.
- Optional length of lift, push button cord and power supply cable besides standard is available on your request.
- Extending the load chain is prohibited with additional links.
- Steel chain containers are available as option as shown in Section of "Chain Containers" if your lift is more than capacity of the standard container volume.

Specifications

Capacity (t)	Product Code	ER2										TSG		Test Load (t)	Net Weight (kg)	Additional Weight per 1m Lift (kg)	
		Hoist Body	Standard Lift (m)	Lifting Motor		Lifting Speed (m/min)		Load Chain		Classification ISO/FEM /ASME	Folded Hand Chain Length E (m)	Flange Width B (mm)					Min. Radius Curve (mm)
				Output (kW)	Rating (%ED)	50Hz	60Hz	Diameter (mm)	Chain Falls			Standard	Option W30 (305mm)				
7.5	ER2SG075S	F	3	3.5	60	1.9	2.3	ø11.2 x 3		M4/1Am /H4	3.2	150 to 220	221 to 305	3000	9.4	275	9.3
10	ER2SG100L					1.4	1.7	ø11.2 x 4							12.5	308	12
	ER2SG100S			2.9	3.5	ø11.2 x 4		395	19								
15	ER2SG150S			3.5x2		1.9	2.3	ø11.2 x 6			18.8	563	19				
20	ER2SG200S					1.4	1.7	ø11.2 x 8		3.7			∞	25	621	24	

Note: Trolley wheels for tapered I-beam are provided as standard. The wheels for flat flange beam are also available so make a request in advance if necessary.

Dimensions (mm)

Capacity (t)	Product Code	Headroom C	D	a	b	e	e'	g	h	i	j	k	m	n	r	t	u	w
7.5	ER2SG075S	1165	1230					61			87							662
10	ER2SG100L	1180	1210	372	480			80			77			196.5				718
	ER2SG100S		1020		531		185	155	77	171			153	70	214	956		
15	ER2SG150S	1310	1230	1012	1000		223	86			82		269	520				1129
20	ER2SG200S	1345	1230	1012	1000			102			77							1305



PAVLÍNEK[®]
VÁZACÍ PROSTŘEDKY

EMAIL: OBCHOD@PAVLINEK.CZ
TEL: +420 595 693 911
ŠALOUNOVA 746/31, OSTRAVA VÍTKOVICE
IČ: 25358511 DIČ: CZ25358511



TWER2M Twin Hook



KITO Twin Hook electric chain hoist, which is equipped with a single motor and two hooks, is intended to lift the hooks horizontally, equally and safely. This product is the most suitable for lifting applications requiring two lifting points for a wide load or retaining a level lifting. For special requirements such as dual speed or curve beam, consult with the nearest KITO dealer.

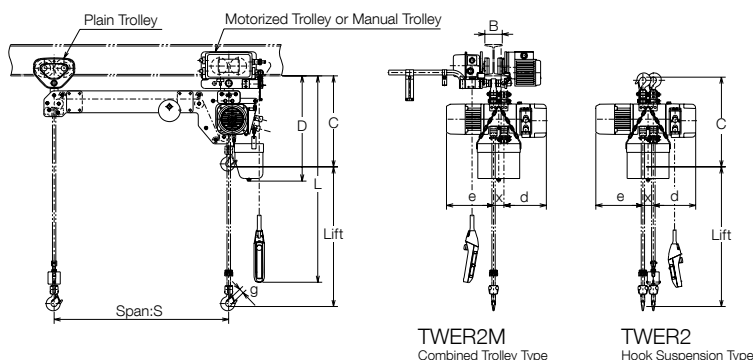

Specifications

Capacity (t)	Product Code	Hoist Body	Standard Lift (m)	ER2				Trolley				Test Load (t)			
				Lifting Motor		Lifting Speed (m/min)		Load Chain		Traversing Motor			Traversing Speed (m/min)		Flange Width B (mm)
				Output (kW)	Rating (%ED)	50Hz	60Hz	Diameter (mm) x Chain Falls	Output (kW)	Rating (%ED)	50Hz		60Hz		
125kg + 125kg	TWER2M003S	C		0.56	60	9.2	11.0	ø6.0 x 2					156kg x 2		
250kg + 250kg	TWER2M005L					3.8	4.6							ø7.7 x 2	0.4
	TWER2M005S	7.3	8.8	ø10.2 x 2					82 to 178						
500kg + 500kg	TWER2M010L	D	3							0.9	60	3.5	4.2	ø10.2 x 2	
	TWER2M010S			7.1	8.5	ø10.2 x 2							100 to 178		
1 + 1	TWER2M020L	E		1.8	60					3.7	4.4			ø10.2 x 2	
	TWER2M020S					7.0	8.4	ø10.2 x 2							
1.5 + 1.5	TWER2M030S	F		3.5	60	4.4	5.3							ø11.2 x 4	
2.5 + 2.5	TWER2M050S					2.9	3.5	ø11.2 x 4	0.75						

Note: The bracketed figures in Traversing Speed are low speed. This product is designed for straight beams. Specify a beam width at the time of quotation or order. The following information will be provided upon your request: 1) precise weight depending on length of the hook span 2) availability of curve beams 3) availability of a lift exceeding the maximum (8m)

Dimensions (mm)

Capacity (t)	Product Code	Headroom C		D	S	d	e	g	x
		With Trolley	Hook						
125kg + 125kg	TWER2M003S	535	525	620	Min. 510	242	271	27	60
250kg + 250kg	TWER2M005L						268		
	TWER2M005S	615	620	710	Min. 530	291	298	31	71
500kg + 500kg	TWER2M010S						307		
1 + 1	TWER2M020L	800	830	790	Min. 650	308	345	39	81
	TWER2M020S						347		
1.5 + 1.5	TWER2M030S	970	995	920				44	
2.5 + 2.5	TWER2M050S	1020	1025	990				47	85

Note: Maximum hook span (S) is 4m. Longer span is also available so contact the nearest KITO dealer.



PAVLÍNEK[®]
VÁZACÍ PROSTŘEDKY

EMAIL: OBCHOD@PAVLÍNEK.CZ
TEL: +420 595 693 911
ŠALOUNOVA 746/31, OSTRAVA VÍTKOVICE
IČ: 25358511 DIČ: CZ25358511



SHER2M Ultra Low Headroom



KITO Ultra Low Headroom electric chain hoist is uniquely designed to have a shorter headroom than that of standard ER2 configurations. This product is the most suitable for installation which requires a low ceiling of buildings or maximizes effective lift. The trolleys are available as option. For special requirements such as rated capacity over 10t, dual speed or curve beam, consult with the nearest KITO dealer.

Headroom Comparison

Capacity (t)	Code	Headroom C(mm)		
		Ultra Low Headroom	Standard ER2M	Difference
250kg	003S	265	375	-110
500kg	005L	285	395	-110
	005S			
1	010L	345	435	-90
	010S			
1.5	015S	435	505	-70
2	020L	445	570	-125
	020S	475	585	-110
3	030S	610	765	-155
5	050S	670	840	-170

Load Factor & Number of Starts for replacement

Load chain periodical replacement is recommended for breakage prevention

Load Factor	100%	75%	50%	25%
Number of Starts	20,000	60,000	200,000	400,000

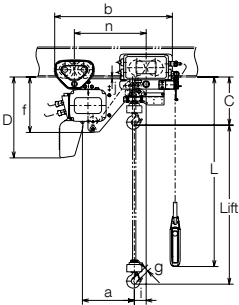

SHER2M
Motorized Trolley Type

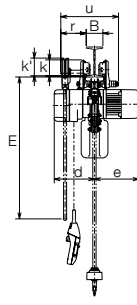

SHER2SG
Geared Trolley Type

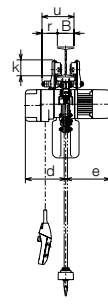

SHER2SP
Plain Trolley Type



PAVLÍNEK
VÁZACÍ PROSTŘEDKY

EMAIL: OBCHOD@PAVLÍNEK.CZ
TEL: +420 595 693 911
SALOUNOVA 746/31, OSTRAVA VÍTKOVICE
IČ: 25358511 DIČ: C225358511



Specifications

Capacity (t)	Product Code	Hoist Body	Standard Lift (m)	ER2				Trolley				Test Load (t)	Net Weight (kg)			
				Lifting Motor		Lifting Speed (m/min)		Load Chain	Traversing Motor		Flange Width B (mm)		Motorized Trolley	Geared Trolley	Plain Trolley	
				Output (kW)	Rating (%ED)	50Hz	60Hz		Diameter x Chain Falls (mm)	Output (kW)						Rating (%ED)
250kg	SHER2M003S	B	3	0.56	60	9.1	11.0	ø4.3 x 1	0.4	40	20 (10)	24 (12)	313kg	78	61	56
500kg	SHER2M005L	C				3.8	4.6	ø6.0 x 1						84	67	62
	SHER2M005S		7.3	8.8	ø6.0 x 1	90	73	68								
1	SHER2M010L	D	3	0.9	60	3.5	4.2	ø7.7 x 1	0.4	40	20 (10)	24 (12)	1.25	104	87	82
	SHER2M010S					7.1	8.5	ø7.7 x 1						124	107	102
1.5	SHER2M015S	E	3	1.8	60	4.5	5.8	ø10.2 x 1	0.4	40	20 (10)	24 (12)	1.88	158	139	134
2	SHER2M020L	F				3.7	4.4	ø10.2 x 1						162	143	138
	SHER2M020S		5.7	6.8	ø11.2 x 1	212	193	188								
3	SHER2M030S	E	3	3.5	60	3.5	4.2	ø10.2 x 2	0.75	40	20 (10)	24 (12)	3.75	241	222	217
5	SHER2M050S	F				2.9	3.5	ø11.2 x 2						322	307	300

Note: The bracketed figures in Traversing Speed are low speed. This product is designed for straight beams. Specify a beam width at the time of quotation or order. The following information will be provided upon your request: 1) availability of curve beams 2) availability of a flange width exceeding the maximum.

Dimensions (mm)

Capacity (t)	Product Code	Headroom C	D	E	a	b	d	e	f	g	h	i	j	k	k'	n	o	p	r	u
250kg	SHER2M003S	265	430		260	656(616)	219	259	325			68				380				
500kg	SHER2M005L	285	520	3700	310	706(666)	242	271	370	27		70	18	95	107	430	515	220	152(56)	345(249)
	SHER2M005S				268	370	130	70	18	95	107	430	515	220	152(56)	345(249)				
1	SHER2M010L	345	540	3700	339	734(694)	291	298	405	31		77				458				
	SHER2M010S				307	405	31	77												
1.5	SHER2M015S	435	640	3700	389	826(803)	308	338	487	34						523				
2	SHER2M020L	445			389	826(803)	308	338	487	34								523	520	225
	SHER2M020S	475	830	423	846(823)	337	399	527	39	125	79	29	112	109	543					
3	SHER2M030S	610	840		438	892(884)	347	356	487	44	131	45	24	134	115	560	521	226	157(79)	398(320)
5	SHER2M050S	670	850	4200	475	1057(1057)	337	399	542	47	145	66	31	144	131	657	528	281	156(53)	401(297)

Note: The bracketed figures in Size "b" are for geared or plain trolley. The bracketed figures in Size "r" or "u" are for plain trolley. Size "D" is for a lift of 4m. This information which varies depending on the lift is provided upon your request.



Mechanical Brake with Friction Clutch

KITO's own device combining functions of friction clutch and mechanical brake for the capacities of 5 t or less, which requires additional components. (Request at placing an order of the hoists)



Overload Limiter

For additional security, Overload Limiter (OLL) is recommended as an option which is preset by 115% of rated capacity. OLL protects the hoist mechanism from damage under overload conditions. (a load can be lowered even after OLL sets off.)

- Standard setting: 115%±8%* of rated capacity
- Adjustable setting: from 90%-135% of rated capacity

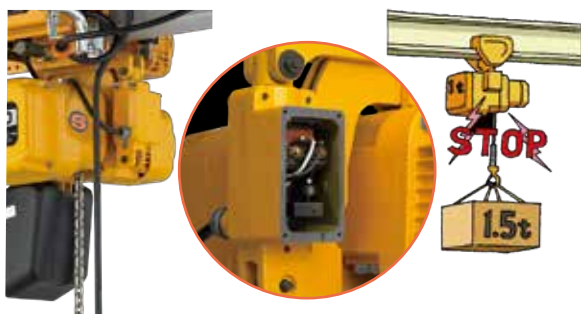

Load Bell

KITO Load Bell has accuracy of alerting you when your hoist is overloaded. This bell helps increase the safety and efficiency of your operations with economical cost.



Extra headroom & weight with KITO Load Bell

Rated capacity (t)	Load chain diameter x chain fall (mm)	Extra headroom (mm)	Weight (kg)
500kg	6.0x1	170	3
1	7.7x1	185	4
1.5	10.2x1	230	5
2	10.2x1	110	8
2.5	11.2x1	120	8
3	10.2x2	115	10

- Setting: 100-110 % of rated capacity
- Power supply: DC 9V (9V dry battery)
- Service life of battery: 700H in intermittent use (4hr per day)
- Alerting buzzer volume: Min. 85dB
- Enclosure: IP55

Drop Stops

Provides additional security of the motorized trolley for the operator and the equipment.

Rubber Bumpers

Provides protection of the motorized trolley from collisions.

Hook Dimensions

Product Code	Top Hook (mm)						Bottom Hook (mm)					
	D	g	i	j	k	l	D	g	h	f	e	c
ER2-001H/IH												
ER2-003S/IS												
ER2-003H/IH	35.5	27.0	17.5	23.5	28.0	17.5	35.5	27.0	17.5	23.5	28.0	17.5
ER2-005L/IL												
ER2-005S/IS												
ER2-010L/IL	42.5	31.0	22.5	31.0	36.5	22.5	42.5	31.0	22.5	31.0	36.5	22.5
ER2-010S/IS												
ER2-015S/IS							47.5	34.0	26.5	36.5	43.5	26.5
ER2-020L/IL	53.0	39.0	31.5	43.5	51.5	31.5						
ER2-020S/IS							53.0	39.0	31.5	43.5	51.5	31.5
ER2-025S/IS			32.5	44.0	52.0	32.5						
ER2-030S/IS	60.0	44.0	34.5	47.5	56.0	34.5	60.0	44.0	34.5	47.5	56.0	34.5
ER2-050S/IS	63.0	47.0	42.5	56.0	67.0	42.5	63.0	47.0	42.5	56.0	67.0	42.5

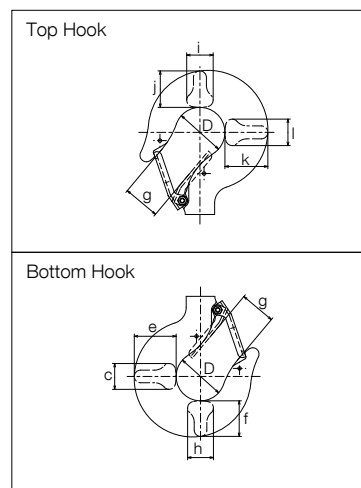

Net Weight List (With Mechanical Brake with Friction Clutch) Standard 3m Lift

Capacity & Lifting Speed Code		Additional Chain Weight per 1m (kg)		With Standard 3m Lift (kg)			
		ER2,MR2,TSP	TSG	ER2	ER2M	ER2SG	ER2SP
125kg	001H	0.42	1.4	28	59	41	33
	001IH			29	61		34
	001HD			32	67		-
250kg	003S	0.42	1.4	28	59	41	33
	003IS			29	61		34
	003SD			32	67		-
	003H	0.81	1.7	38	69	51	43
	003IH			71			
500kg	005L	0.81	1.7	37	67	49	42
	005IL				69	-	-
	005LD			43	77	-	-
	005S			38	69	51	43
	005IS				71		
	005SD			44	78	-	-
1t	010L	1.33	2.3	50	80	62	58
	010IL			49	81	61	57
	010LD			58	92	-	-
	010S			54	84	66	62
	010IS			53	85	65	61
	010SD			58	92	-	-
1.5t	015S	2.3	3.2	77	115	95	91
	015IS			78	118	96	92
	015SD			80	122	-	-
2t	020L	2.3	3.2	79	116	96	92
	020IL			119			
	020LD			82	123	-	-
	020S			90	128	108	104
	020IS			92	132	110	106
	020SD			96	138	-	-
2.5t	025S	2.8	3.7	103	151	131	127
	025IS			106	157	134	130
	025SD			107	159	-	-
3t	030S	4.7	5.6	107	155	133	129
	030IS			109	160	136	132
	030SD			112	163	-	-
5t	050S	5.6	6.5	130	200	186	180
	050IS			134	206	190	184
	050SD			133	207	-	-

Applications



PAVLÍNEK
VÁZACÍ PROSTŘEDKY

EMAIL: OBCHOD@PAVLINEK.CZ
TEL: +420 595 693 911
ŠALOUNOVA 746/31, OSTRAVA VÍTKOVICE
IČ: 25358511 DIČ: CZ25358511





EMAIL: OBCHOD@PAVLINEK.CZ
 TEL: +420 595 693 911
 ŠALOUNOVA 746/31, OSTRAVA VÍTKOVICE
 IČ: 25358511 DIČ: CZ25358511

PAVLÍNEK
 VÁZACÍ PROSTŘEDKY



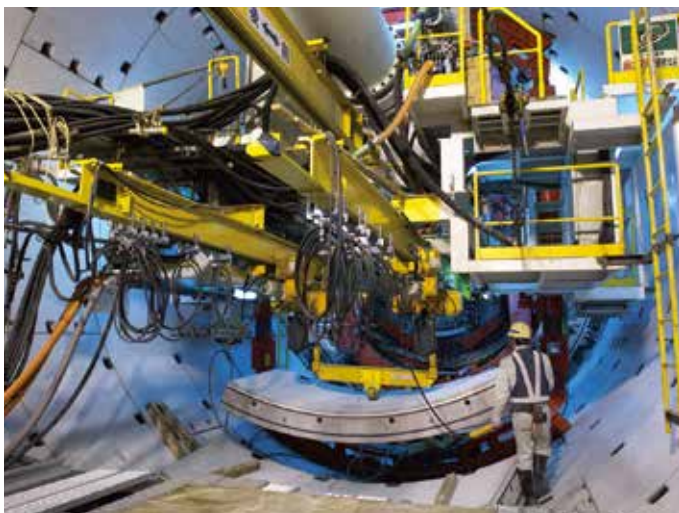

EMAIL: OBCHOD@PAVLINEK.CZ
 TEL: +420 595 693 911
 ŠALUNOVA 746/31, OSTRAVA VÍTKOVICE
 IČ: 25358511 DIČ: CZ25358511

PAVLÍNEK
 VÁZACÍ PROSTŘEDKY



KITO



Head Office & Factory

2000 Tsuijijarai Showa-Cho, Nakakoma-Gun, Yamanashi 409-3853, Japan
TEL: +81-55-275-7521 FAX: +81-55-275-6162

Tokyo Head Office

SHINJUKU NS Bldg. 9F, 2-4-1 Nishi-Shinjuku, Shinjuku-ku, Tokyo 163-0809, Japan
TEL: +81-3-5908-0180 FAX: +81-3-5908-0189
www.kito.co.jp/en KITO Global Website: kito.com

International Sales Subsidiaries

U.S.A.

Harrington Hoists, Inc.

401 West End Avenue, Manheim, PA 17545, U.S.A.
TEL: +1-717-665-2000 FAX: +1-717-665-2861
www.harringtonhoists.com/

PEERLESS INDUSTRIAL GROUP, INC.

1416 East Sanborn St. Winona, MN 55987, U.S.A.
TEL: +1-800-873-1916 FAX: +1-800-356-1149
www.peerlesschain.com/

CANADA

KITO CANADA INC.

309-3815 1st Ave., Burnaby, BC V5C 3V6, Canada
TEL: +1-604-291-9955 FAX: +1-604-294-8855
www.kito.ca/

BRAZIL

KITO DO BRASIL COMÉRCIO DE TALHAS E GUINDASTES LTDA

Unidade 38 do CLE – CENTRO LOGÍSTICO EMBU
Rua José Semião Rodrigues Agostinho, 1370,
Bairro Água Espraiada – Embu das Artes, SP, Brasil
TEL: +55-11-3253-1000 FAX: +55-11-3253-1008
http://www.kito.com/br/

GERMANY

Kito Europe GmbH

Heerdter Lohweg 93, D-40549 Düsseldorf, Germany
TEL: +49-(0)211-528009-00 FAX: +49-(0)211-528009-59
www.kito.net/

ITALIA

Kito Chain Italia S.r.l.

Via Giuseppe Verdi 11, 33018, Tarvisio (Ud), Italia
TEL: +39-(0)428-4171 FAX: +39-(0)428-417301

AUSTRALIA

KITO PWB

441 Grimshaw Street, Bundoora, VIC 3083, Australia
TEL: +61-1300-792-262 FAX: +61-3-9467-7290
www.pwbanchor.com.au/

CHINA

JIANGYIN KITO CRANE CO., LTD.

18 Cheng Jiang East Road, Jiang Yin, Jiang Su 214429, China
TEL: +86-510-86199700 FAX: +86-510-86196633
www.kaicheng.com/

SHANGHAI KITO TRADING CO., LTD.

Room 11J, Zao-Fong Universe Building,
No1800 ZhongShan West Road Shanghai 200235, China
TEL: +86-21-54488935 FAX: +86-21-54488937
www.kito.com.cn/

TAIWAN

KITO TAIWAN CO., LTD.

12F-1, 128c sec. 3, Ming-Shen East Road, Taipei, Taiwan 10596
TEL: +886-2-2719-7616 FAX: +886-2-2719-6900
www.tw.kito.com/

KOREA

KITO KOREA CO., LTD.

3Dong 903, 15, Pangyo-Ro 228Beon-gil, Bundang-gu,
Seongnam-si, Gyeonggi-do, Korea 13487
TEL: +82-31-600-7450 FAX: +82-31-600-7469
www.kito.kr/

THAILAND

SIAM KITO CO., LTD.

205 M.2, T.Klongtumru, A.Muangchonburi, Chonburi 20000, Thailand
TEL: +66-3819-5711 FAX: +66-3846-8195
www.siamkito.co.th/

INDIA

Armsel MHE Pvt. Ltd.

Sy No 118/2 of Jakkur Village, 80 Feet Road, Jakkur Post,
Yelahanka Hobli, Bengaluru – 560064, Karnataka, India
TEL: +91-80-49010500 FAX: +91-80-49010555
enquiry@armsel.com www.armsel.com

INDONESIA

PT. KITO INDONESIA

Wisma Keiai 5F, Jl. Jend. Sudirman Kav.3-4, Jakarta 10220
TEL: +62-21-572-4261 FAX: +66-3819-5715
kito.com/id/

- The functions and performance of the products mentioned in the catalog have been designed based on the related regulations and standards.
If they are used for other than their intended purposes such as being integrated into your equipment,
we will not take any responsibility for accidents attributable to their unintended usages as well as guarantee their performance and functions. Never remodel our products.
- When you want to use our products for special purposes, consult us in advance.
- When you want to export our products, consult us in advance. There are different standards and regulations from one destination to another.
- It is prohibited to reprint, copy or divert all the information in this catalog (product patents, trademarks, photos, designs, copies, illustrations, etc.) without our consent.
- The specifications in this catalog are partly subject to change without prior notice.
- Product specifications may vary depending on the country. For more details please contact the nearest KITO dealer.

Distributed by:



PAVLÍNEK[®]
VÁZACÍ PROSTŘEDKY

EMAIL: **OBCHOD@PAVLINEK.CZ**
TEL: **+420 595 693 911**
ŠALOUNOVA 746/31, OSTRAVA VÍTKOVICE
IČ: **25358511** DIČ: **CZ25358511**

